

**- QUICKGUIDE -**



Flanged end connection



Spigot end connection

**Table of contents**

1.	Intended use / product description	Page 2
2.	Assembly	Page 2
2.1	General	Page 3
2.2	Seeping water drain packing	Page 3
2.3	Drainage element	Page 3
2.4	Seepage hose	Page 3
2.5	Drainage hose PE d20	Page 4
2.6	Shortening	Page 4
3.	Commissioning and pressure testing	Page 4
3.1	Commissioning	Page 5
3.2	Pressure testing	Page 5
3.2.1	Pressure testing of pipeline	Page 5
3.2.2	Pressure testing of installed air valve	Page 6
4.	Commissioning/Pressure test	Page 6
5.	Special functions	Page 6
5.1	Special function - installation in flood water areas / flood protection	Page 6
5.2	Special function - installation in groundwater	Page 6
5.3	Special function - air intake only or air release only	Page 6
5.4	Special function - with closing aid Art. No. 009 878 1570	Page 6
5.5	Special function - anti-frost disc Art. No. 992 200 1050	Page 6
5.6	Special function - special insect and snail protection Art. No. 992 200 1010	Page 6
5.7	Special function - screw lock Art. No. 992 200 1100	Page 6
	Parts list Havent® air valve set	Page 7
	Parts list Havent® air valve	Page 8

## 1. Intended use / product description

<b>Medium:</b>	potable water
<b>Working range::</b>	0 - 16 bar
<b>Material:</b>	see parts list
<b>Possible connections:</b>	flange DN50, DN80 BAIO spigot end DN80
<b>Pipe cover depths:</b>	1,0 m, 1,25 m, 1,5 m, 1,75 m ( can be shortened on site by 100mm, see item 2.3 )

The air valve set (AVS) consists of a shaft with a shut-off facility and an air valve (AV). Due to its compact design, the AVS replaces costly and high-maintenance manhole constructions. All maintenance and repair work can be carried out from the road surface, thus avoiding the dangers possibly related with the access of manholes.

The HaVent® air valve featuring the roll-on diaphragm technology is perfectly suitable for taking in and releasing high amounts of air during filling or draining of pipelines and for releasing major amounts of air during operation within operating range. The AV operates continuously from 0 to 16 bar, perfectly sealing even in unpressurized condition. No minimum response pressure is needed. The sealing principle with a roll-on diaphragm helps to absorb pressure surges.

Due to the high air intake capacity, the AV is additionally provided with effective vacuum protection.

Max. air release capacity: 770 m<sup>3</sup>/h (on filling the pipeline)

Max. release cross section: 1,500 mm<sup>2</sup>

Max. cross section for in-service venting: 200 mm<sup>2</sup>

### Product identification AV inside:



**Nennweite / Size:**  
BEG

**Druckstufe:**  
**max. pressure:**  
PN16  
250 psi

**Gehäuse/Body:**  
Edelstahl  
stainless steel

**European standard:**  
EN 1074-4  
DVGW\_W

**Herstelljahr:**

**Year of manufacture:**  
xxx

**Seriennummer:**  
**Serial No.:**  
xxx

Made in Germany

### Product identification AVS outside

**Be- und Entlüftungsgarnitur**

**DN xx**

**Flansch / BAIO-Spitzende**

**DN 2“  
Havent**

**PN 0 - 16 bar**

**Gesamtlänge: xxx**

**Baujahr: xxx**

**Art.Nr. xxx**

Made in Germany

During installation and maintenance operations, the applicable standards and guidelines, accident prevention regulations and the regulations of professional associations are to be observed and complied with. Installation and maintenance operations may be performed by qualified personnel only.

## 2. Assembly

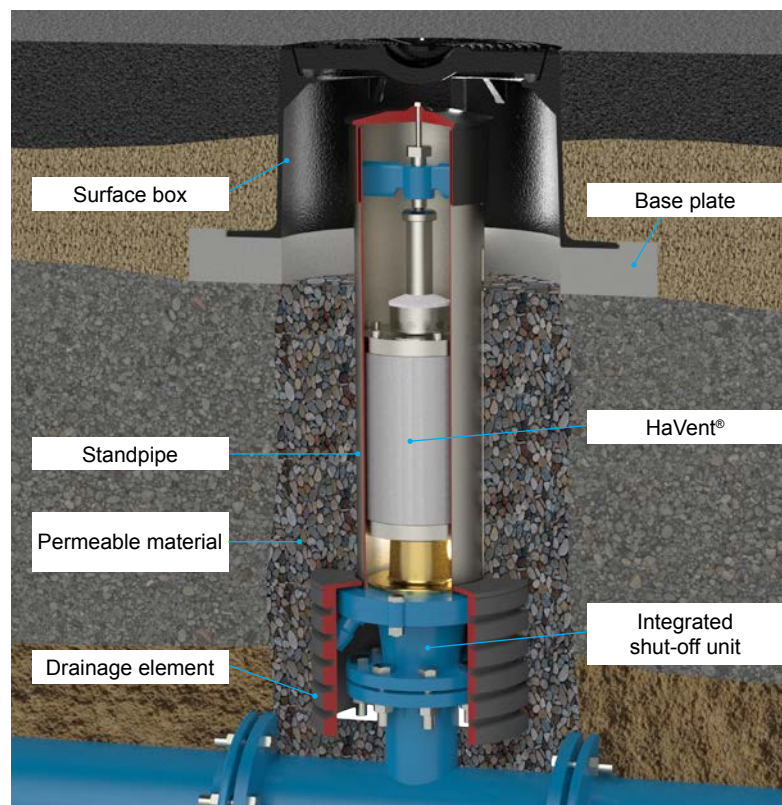



2x open-ended wrench A/F 24 (version with flange), socket wrench A/F 13

## 2.1 General

Air valves and air valve sets are installed at high points, at points of change in pipe inclination, in descending line sections, in case of slightly descending or horizontal pipe runs, upstream and downstream of control valves, as well as downstream of pumps.

For detailed planning specifications for new construction and retrofitting, please refer to the technical information for planners regarding air valves and air valve sets, as well as the current DVGW sheet W334.

The AV and/or AVS has to be installed on a vertical outlet directly on the pressure pipe. The need for an air release dome as specified in DVGW sheet W334 has to be checked. A laterally displaced arrangement of air valves / air valve sets must be avoided.

Installation shall be performed in unpressurized condition.

For installing the AVS on the pipeline, the respective DVGW provisions for establishing a flanged connection and/or the BAIO installation instructions shall be observed.



**Important:** For the connection variant with BAIO® spigot end, the dirt cover and locking ring Ord. No. 490-05 shall be used.

If there is a risk of frost, the AVS must be provided on site with frost-proof insulation (see also item 5.4).

## 2.2 Seeping water drain packing

To prevent surface water from running in, the shaft pipe must be surrounded with permeable backfilling (grain size > 5 mm). Maximum filling height see image.

Approx. 3-5 cm distance

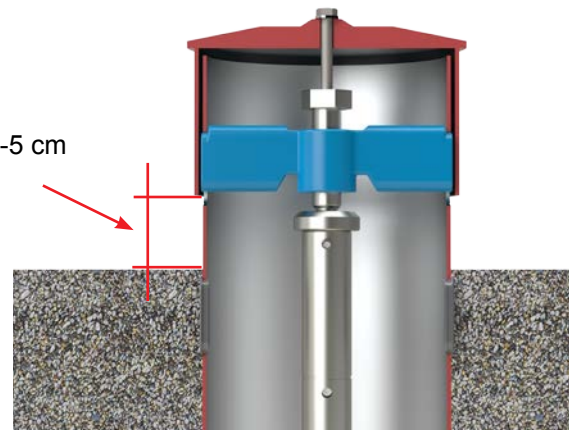

We recommend installing a drainage element Ord. No. 992-03, or alternatively a seepage hose Ord. No. 992-04 in connection with permeable backfilling.

## 2.3 Drainage element Ord. No. 992-03

The drainage element for AVSs serves the purpose of receiving and slowly draining off the splash water accumulating inside the AVS (originating during air release) and the residual water accumulating on dismantling the valve. Additionally, a possible penetration of roots is prevented.

### Use in:

- Normal soils
- Installation situations where no mud is expected to be washed into the housing (no groundwater).

### Installation:

1. Remove the hood (10) from the AVS. To this end, loosen hexagon head screw M8 (8) and washer (10).
2. Put the drainage element (stop ring on top) over the shaft pipe from above and push it downward as far as it will go.
3. Reinstall the hood (10) with hexagon head screw M8 (8) and washer (10).
4. Surround the drainage element with permeable backfilling.

## 2.4 Seepage hose Ord. No. 992-04

The seepage hose for AVSs serves the purpose of receiving and slowly draining off the splash water accumulating inside the AVS (originating during air release) and the residual water accumulating on dismantling the valve. Additionally, a possible penetration of roots is prevented.

The seepage hose consists of a flexible drainage pipe d 50 mm wrapped in filter fleece. Via the big surface area, the accumulated splash water / residual water is released evenly.

The filter fleece reduces the penetration of fine soil material into the interior of the AVS via the seepage hose.

### Use in:

- "Fine-textured" soils
- Installation situations where mud is expected to be washed into the housing (groundwater).

### Installation:

See operating instructions "Seepage Hose for Air Valve Set".

## 2.5 Drainage hose PE d20

If the drainage element Ord. No. 992-03 or seepage hose Ord. No. 992-04 is not used, the supplied drainage hose PE d20 can be used for draining off the accumulating splash water into an additional seeping water drain packing. To this end, push the hose into the drain-off fitting (2) as far as it will go. For installation, moisten the pipe end with water.

## 2.6 Shortening



Socket wrench A/F 13, A/F 30, fitting grease, e.g. Art. No. 600 000 0015  
Angle grinder with cutting disc for stainless steel, pin punch

Prior to installation, the AVS can be shortened on site by 100 mm to adapt it to changed height conditions.

**⚠ Important:** In case of the version with pipe cover depth 1.0 m **with** special function "Air release only" or "Air intake only", shortening is not possible!

Sequence:

1. Take off the hood (10). To this end, loosen hexagon head screw M8 (8) and washer (9).
2. Loosen the centring screw (11) and take out the clamping yoke / spindle holder (12).
3. Take out the whole replacement set and put it aside protected from dirt.

#### 4. Shortening the shaft pipe: ( see Figure 1 )

Put the hood (10) loosely onto the shaft pipe. Mark a line for shortening along the lower hood edge (corresponding to max. shortening by 100 mm). Shorten the shaft pipe using an angle grinder and cutting disc for stainless steel. Deburr the cut surface.



Figure 1

#### 5. Shortening the replacement (see Figure 2)::

Dismantle the centring cap (6.16) from the operating tube (6.18). To this end, remove the roll pin (6.17) by means of the pin punch. Shorten the operating tube at the specified marking (see figure) using an angle grinder and cutting disc for stainless steel. Deburr the cut surface.



Figure 2

6. Reinstall the centring cap (6.16) and roll pin (6.17) on the shortened operating tube.
7. Reinsert the replacement set through the shaft pipe (7) into the sealing flange (3). To this end, press the replacement set into the sealing flange (3) applying manual force until you feel high resistance.
8. Subsequently, insert the clamping yoke / spindle holder (12) into the shaft pipe (7), and brace the replacement set again by turning in the centring screw (8) 2-3 revolutions.
9. Reinstall the hood (10) with the hexagon head screw (8) and washer (9).

**⚠ Important:** If a flushing and water tapping set Ord.No.992-05 und 992-06 is used for a shortened AVS, the extended clamping yoke Ord. No. 992-07 is needed (Figure 3).



Figure 3

## 3. Commissioning and pressure testing



Socket wrench A/F 13, A/F 30

### 3.1 Commissioning

For commissioning, the unpressurized line shall be filled and pressurized.



**Important:** Acc. to DVGW W334, the maximum filling rate must be limited to 0.25 m/s to avoid pressure surges.

**Note:** During start-up ventilation, a minor quantity of splash water is blown off via the valve.

Prior to commissioning, we recommend flushing to remove possible dirt accumulations at the high point of the pipeline (right column).

Alternatively, commissioning can be performed without flushing (left column).

Commissioning with automatic venting Important: Malfunction caused by dirt ingress is possible!	Commissioning with flushing and water tapping set
1. Take off the hood (10). To this end, loosen hexagon head screw M8 (8) and washer (9).	1. Take off the hood (10). To this end, loosen hexagon head screw M8 (8) and washer (9).
	2. Loosen the centring screw (11) and take out the clamping yoke / spindle holder (12).
	3. Take out the whole replacement set (6) and put it aside protected from dirt.
	4. Install the flushing and water tapping set Ord. No. 992-05, 992-06. See operating instr. "Flushing and Water Tapping Set".
	5. Fix it by means of the clamping yoke / spindle holder (12) and centring screw (11).
	6. Slowly open the ball valve at the flushing and water tapping set.
2. Fill the pipeline (filling rate acc. to DVGW W334, see above).	7. Fill the pipeline (filling rate acc. to DVGW W334, see above).
3. Air and/or air/water mixture escapes. Dirt possibly present in the line accumulates in the AV. Consequence: AV does not close any more. Perform maintenance as described in item 4.	8. Air and/or air/water mixture escapes together with any possible dirt. Continue flushing until only clear water escapes.
4. After filling is finished, the AV closes automatically.	9. Close the ball valve at the flushing and water tapping set very slowly (danger of water hammers).
5. To be able to perform the subsequent pressure test described in item 3.2, the following sequence must be observed:	10. Perform pressure test described in item 3.2.
6. Loosen the centring screw (11) until the clamping yoke / spindle holder (12) is loosened. Consequently, the complete replacement set is also loosened as well as unpressurized, since the sealing tappet (4) closes automatically.	
7. Perform pressure test described in item 3.2.	

### 3.2 Pressure testing

#### 3.2.1 Pressure testing of the pipeline

The pressure test of the pipeline with the installed AVS in the open trench shall be performed considering the maximum operating pressures as specified in the DVGW regulations.



**IMPORTANT:** The pressure test must be carried out with the replacement set put out of service and/or the flushing and water tapping set installed!

After the successful pressure test, repressurize the replacement set previously put out of service by turning in the centring screw (8) until a distinctive momentary "venting splash" appears.

Then turn in the centring screw (11) by only approx. 1/2 additional turn!

Reinstall the hood (10) with the hexagon head screw (8) and washer (9).

**IMPORTANT:** If a permanent water splash instead of a momentary venting splash appears, maintenance acc. to item 4 must be performed.



### 3.2.2 Pressure testing of the installed AV

After subjecting the pipeline to a pressure test acc. to item 3.2.1 or after successful maintenance, an additional pressure test of the AV considering the maximum operating pressures specified in the DVGW regulations has to be carried out.

Before pressure testing, any flushing and water tapping set used during commissioning must be removed, and the replacement set has to be reinstalled (see item 3.1 / 3. Commissioning with flushing and water tapping set).

## 4. Servicing and maintenance

As specified in the DVGW regulations W400-3, AVSs must be maintained at least once a year. Depending on the composition of the water, it may be necessary to reduce the maintenance intervals. Regular inspection will increase the functional reliability of the AVSs.

For cleaning, we recommend using lukewarm water. Before reinstallation, all components shall be disinfected by means of disinfectants approved for potable water applications observing the manufacturer's instructions.

Foreign matter washed into the valve body (e.g. PE chips left over from drilling, wood, polystyrene, ...) as well as deposits in case of ferrous or manganiferous water qualities may impair the proper sealing function.



**IMPORTANT:** Before maintenance, AVSs shall be put out of service. Maintenance shall be performed in unpressurized condition.

**Always** take the complete replacement set out of the AVS housing for maintenance and service work.

For detailed instructions on servicing and maintenance with a detailed maintenance procedure and spare parts, see the complete version of the AVS Havent® PN16 operating and maintenance instructions, order no. 992-00.



## 5. Special functions

Item	Ord.No./ Art.No.		Ex factory	For retrofitting on site
5.1	992 000 1010 ( 992-08 )	Installation in flood water areas / flood protection	X	
5.2	992 500 1000 - 992 500 1003	Version for groundwater installation	X	
5.3	992 500 0900 - 992 500 0903	Air release only / air intake only	X	
5.4	009 878 1570	Closing aid	X	X
5.5	992 200 1050	Anti-frost disc	X	X
5.6	992 200 1010	Insect and snail protection	X	X
5.7	992 200 1100	Screw lock	X	X

For a detailed description of the special functions, see the complete version of the operating and maintenance instructions.



The maintenance of the AVSs with special functions is carried out in the same way as the descriptions of the standard version.

**If you have any other questions or if you need more information please contact:**

Hawle Armaturen GmbH  
- Application Engineering -  
Liegnitzer Str. 6  
83395 Freilassing  
Phone: +49 (0)8654 6303-0  
Telefax: +49 (0)8654 6303-222  
E-Mail: [info@hawle.de](mailto:info@hawle.de)  
Web: [www.hawle.de](http://www.hawle.de)

# Air valve set HaVent® for potable water PN 16

## Parts list

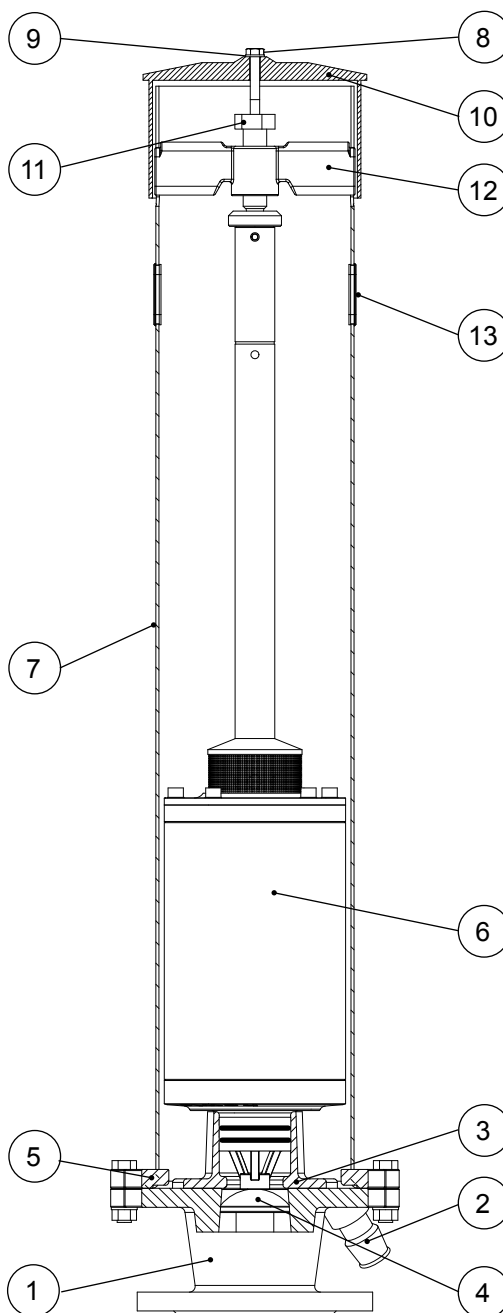

No	Qty	Short description	Material	No	Qty	Short description	Material
1	1	Base	GJS-400 Hawle-epoxy powder coated	7	1	Shaft pipe	Stainless steel
2	1	Drain-off fitting	GJS-400 Hawle-epoxy powder coated	8	1	Hexagon head screw M8x60	Stainless steel
3	1	Sealing flange	Brass	9	1	Washer M8	Stainless steel
4	1	Sealing tappet	POM	10	1	Hood	PE
5	1	Lock ring	GJS-400 Hawle-epoxy powder coated	11	1	Centring screw with ball	Stainless steel
6	1	Replacement set, see separate parts list		12	1	Clamping yoke / spindle holder	GJS-400 Hawle-epoxy powder coated
				13	2	AVS rubber plug	EPDM

# Replacement set HaVent® for potable water PN 16 for air valve set

## Parts list

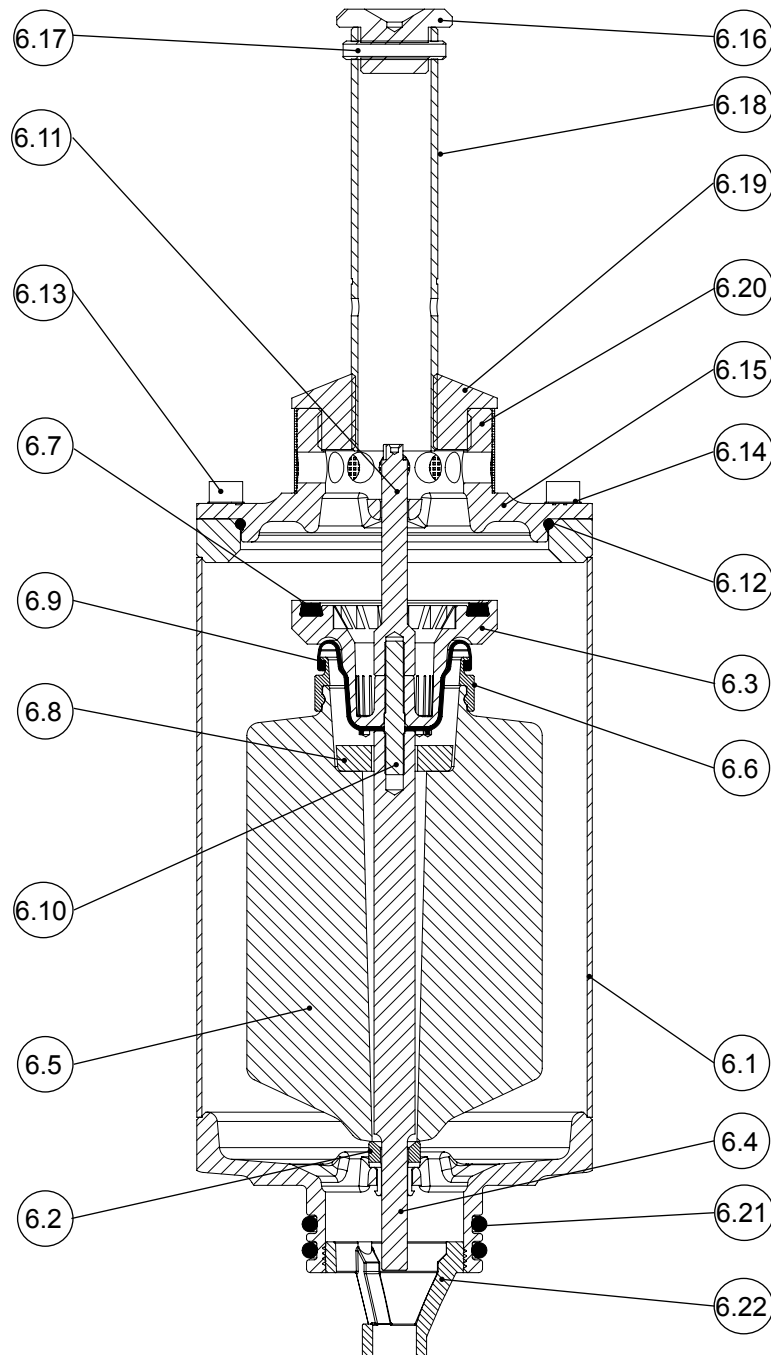

No	Qty.	Short description	Material
6.1	1	Housing	Stainless steel
6.2	1	Closing sleeve	POM
6.3	1	Valve basket	POM
6.4	1	Guide rod	POM
6.5	1	Float	PP
6.6	1	Roll-on diaphragm adaptor	POM
6.7	1	Flat gasket	EPDM
6.8	1	Shim	POM
6.9	1	Roll-on diaphragm	EPDM
6.10	1	Grub screw M8x30	Stainless steel
6.11	1	Guide for valve basket	POM
6.12	1	O-ring 116x4	EPDM
6.13	5	Allen screw M8x16	Stainless steel
6.14	5	Shim ring	Stainless steel
6.15	1	Housing upper part	Stainless steel
6.16	1	Centring cap	Stainless steel
6.17	1	Roll pin	Stainless steel
6.18	1	Operating tube	Stainless steel
6.19	1	Outlet nipple	POM
6.20	1	Mesh hose	Stainless steel
6.21	2	O-ring 60x6	EPDM
6.22	1	Tripod for AVS	PA