

1. Intended use / Product description

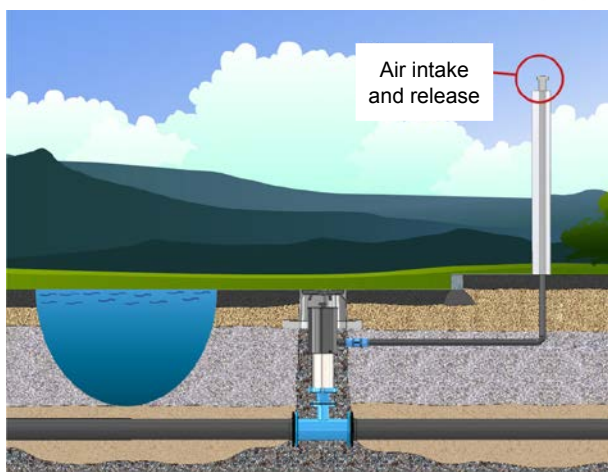

Normal installation situation

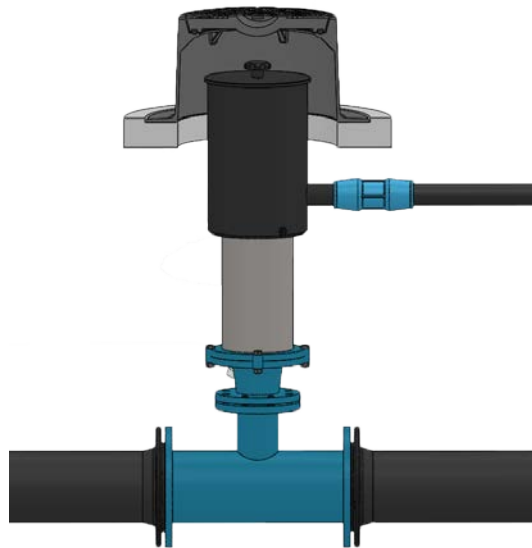
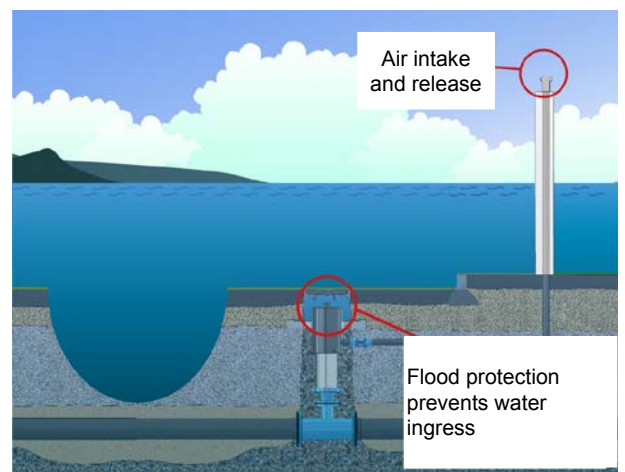

Installation situation when flooded

Medium: Potable Water

Material: Housing / cover / nipple: PE
Allen head screws: stainless steel
Sealing: EPDM

If the air valve set is installed in areas susceptible to flooding, the special flood protection function can prevent dirty water from flowing back into the air valve and subsequently into the potable water system.

Flood protection consisting of a flood hood with cover, sealing plug and outlet connection d 50 mm for air valve sets (Ord. No. 992-00, 992-01, 992-02).

During installation and maintenance operations, the applicable standards and guidelines, accident prevention regulations and the regulations of professional associations are to be observed and complied with.
Installation and maintenance operations may be performed by qualified personnel only.

2. Assembly



1. Loosen the hexagon head screw.



2. Dismantle the black plastic cap.



3. Loosen the centering screw.



4. Dismantle the spindle holder.



5. Remove the sealing caps on both sides.



6. Apply commercial lubricant on the inner seal. Place the flood protection over the standpipe without the lid.



7. Align the horizontal outlet d 50 mm into final position.



8. Fix the flood protection by means of an Allen key.



9. Close the drainage fitting using the supplied plug. **Note:** When factory-mounted, the fitting mechanism is already closed by means of a plug.



10. Place the spindle holder.



11. Screw down the centering screw until the air valve is filled with water.



12. Put the lid onto device and fix it by means of the clamping screw.

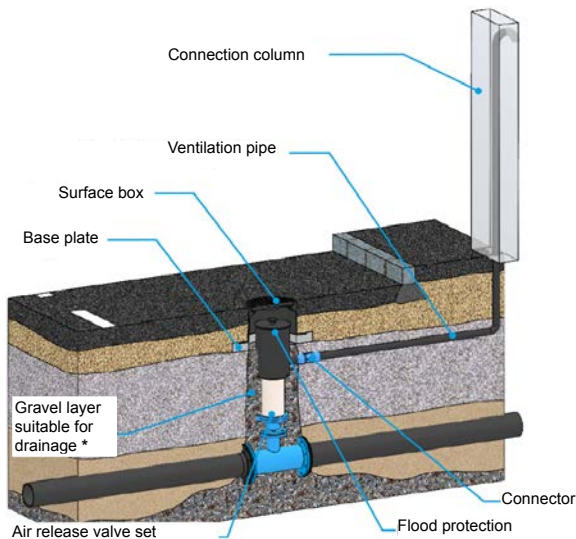

13. Establish a water-proof connection between the vent pipe to be provided by the customer and the horizontal PE outlet d 50mm of the flood protection and pull it upward above the required level (defined flood height). To prevent rainwater from flowing in we recommend providing the vent pipe with a ventilation hood (see figure) and placing it in a connection column as depicted.

* If the air valve set is already installed with the flood protection no seepage material is necessary, as the drainage fitting is sealed (see point 9).

3. Servicing - maintenance

The flood protection for air valve set for potable water is maintenance free.



IMPORTANT: Before maintenance, air valve sets shall be put out of service. Maintenance shall be performed in unpressurized condition.

It must be ensured by carefully monitoring the system that no grey water is allowed to flow back into the potable water pipeline via the vent pipe.

As the drainage fitting of the air release valve set is closed, any splash water that may be accumulating during venting must be pumped out of the set at regular intervals, e.g. by using a hand pump.

4. Commissioning and pressure-testing

For commissioning and pressure testing, see the operating instructions for the corresponding air valve set Ord. No. 992-00, Ord. No. 992-01 and Ord. No. 992-02.

If you have any other questions or if you need more information please contact:

Hawle Armaturen GmbH
- Application Engineering -
Liegnitzer Str. 6
83395 Freilassing
Germany
Phone: +49 (0)8654 6303-0
Telefax: +49 (0)8654 6303-222
E-Mail: info@hawle.de
Web: www.hawle.de