

PRO butterfly valve
with proportional action sealing system
and Hawle loose flanges

Explanatory notes on the brochure

General media information in the product descriptions may apply subject to certain restrictions. Kindly always state the relevant medium in your given application when you place an order or submit a query.

If you have any further questions about our products, please do not hesitate to contact our employees of the application engineering division at any time.



Products for use in connection with potable water



In general, products sold by us are subject to the statutory warranty period of 2 years from the date of delivery at Hawle. Due to the high quality of Hawle products, we are able to offer you an extended warranty of 5 years for products manufactured by us. For more details, please see our website at: www.hawle.de/en/warranty-extension/



Information on our “10-year quality guarantee” for Hawle potable water products are available at the following link: www.hawle.de/en/10-years-quality-warranty/



For current information, please see our Hawle app. Further information is available at www.hawle.de/app

PRO butterfly valve with proportional action sealing system and Hawle loose flanges

The PRO butterfly flap is provided with a proportional action gasket system.

The gasket is accommodated in the body of the butterfly valve. When open, the same pressure is admitted to the valve disc from all sides, thus reliably preventing unintended deformations of the gasket. As soon as the PRO butterfly valve moves to closed position, the valve seal is pressed against the valve disc. The contact pressure depends on the water pressure.

The proportional action sealing system ensures reliable sealing, on the one hand, and a long service life due to low wear of the sealing, on the other hand.

The Hawle PRO butterfly valve is provided with the proven loose flange system of the exchange gate valve. Accordingly, apart from being used in new constructions, the butterfly valve is mainly suitable for exchanging existing valves.

The flat gaskets are already included in the barrel gaskets. Therefore, no keying is required between the flanges. The loose flanges can be moved lengthwise along the butterfly valve and rotatable by up to 360°.

Moreover, the flange system offers some advantages in terms of storage. The flanges can be quickly and easily changed from PN 10 to PN 16 and vice versa.

Apart from its actual function as a shut-off valve, the PRO butterfly valve can also be used as a dismantling piece because of the integrated loose flange system. Accordingly, no additional dismantling piece is required for systems and chambers.

When installed in the ground, the PRO butterfly valve ensures long maintenance-free operation and thus reduces the cost of maintenance effort.

Technical features

- DVGW (German Association for Gas and Water) certification
- Proportional action sealing system
- Easy installation due to loose flange system
- Storage benefits due to exchangeability of loose flanges, e.g. from PN 10 to PN 16
- Flat gaskets are already included in the barrel gaskets
- Self-locking work gear, with position indicator for installation in plants
- Blow-off-resistant fixing of shafts and sleeves (EN 593)
- Maintenance-free

Technical data

Body / flange:	GJS-400, Hawle epoxy powder coating
Valve disc and shaft:	Stainless steel
Seal gasket:	EPDM (reinforced with a ring of stainless steel) according to KTW-BWGL for water (evaluation criteria for products and materials in contact with potable water)
Barrel gasket for loose flange:	EPDM according to KTW-BWGL for water (evaluation criteria for products and materials in contact with potable)
Retaining ring:	POM for DIN 150 - DN 300 / stainless steel as from DN 400
Medium:	Potable water
Operating temperature:	0° - 40°C
Max. operating pressure:	10 bar / 16 bar (depending on loose flange PN16 or PN 10)
Nominal diameters:	DN 150 - DN 600
Face-to-face length:	Basic series 14 according to DIN EN 558-1

Innovative proportional action sealing system in valve body

- Innovative proportional action sealing system in valve body
- Eccentric bearing of valve disc
- Stress-relieved bearing of seat gasket in open position
- Low operating torques
- Maintenance-free

1. Body
2. Steel-reinforced seat gasket
3. Retaining ring
4. Valve disc
5. Loose flange
6. Barrel gasket
7. Locking ring

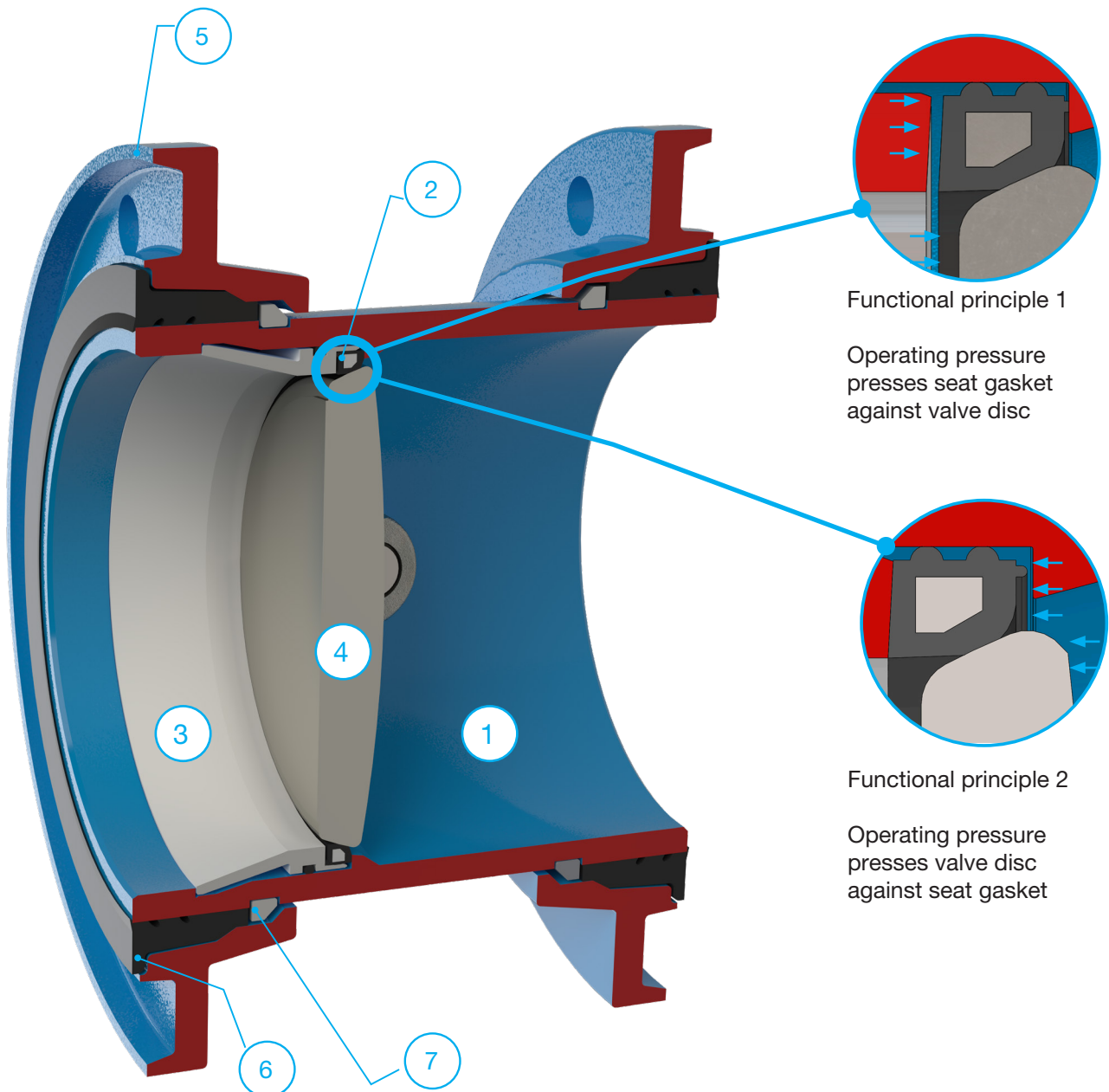

Example illustration: PRO butterfly valve DN 200

Hawle loose flange system, with corrosion protection and restraint

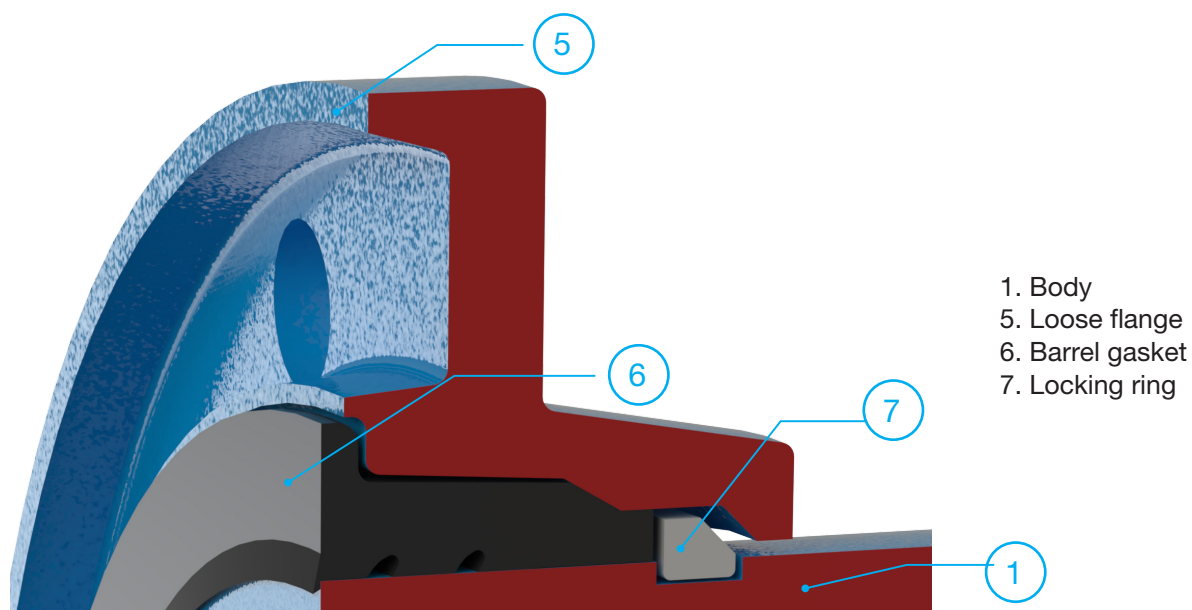

- Two restraint loose flanges (PN 10 or PN 16)
- Flat gaskets are already included in the barrel gaskets -> therefore, no keying is required between flanges when installing the valve in the gap.

Drive variants:

Plant installation

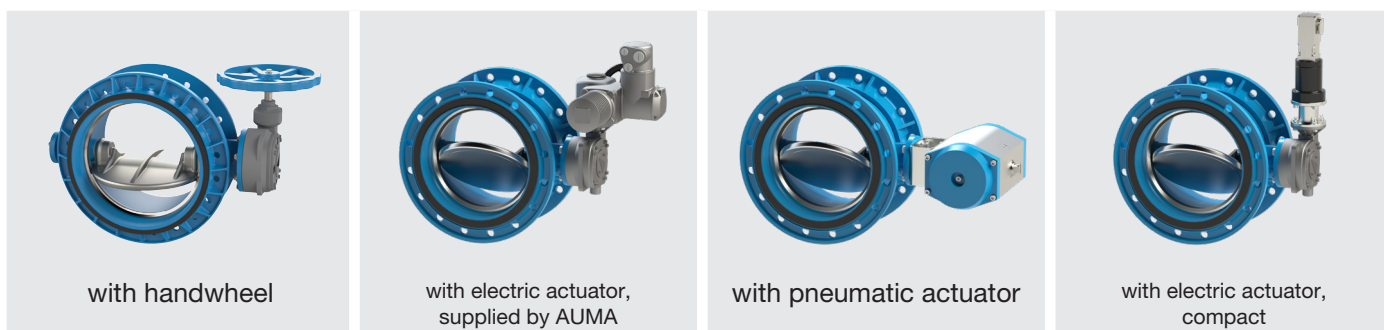

Buried installation



Product supplements



900-01
Rigid extension spindle for
Hawle PRO butterfly valve



950-00
Telescopic extension spindle



952-00
Telescopic extension spindle of
stainless steel



500-01
Support bearing
for Hawle PRO butterfly valve



780-00
Handwheel for butterfly valves

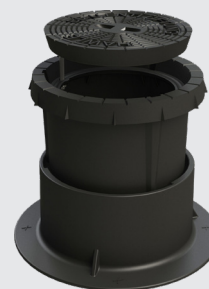

211-04
Surface box for rolling in, with
locking bolt

Maximum operating pressure

No.:	Description		Nominal diameter
900-01	Rigid extension spindle for Hawle PRO butterfly valve	-	Pipe cover depth 1.00 - 1.50 m
950-00	Telescopic extension spindle	-	Pipe cover depth 0.85 - 4.10 m
952-00	Telescopic extension spindle of stainless steel	-	L 550 - 1290 mm
500-01	Support bearing for Hawle PRO butterfly valve <small>For use when an installation site deviates from the standard installation situation (see operating manual for support bearing).</small>	16 bar	DN 150 - DN 600
780-00	Handwheel for butterfly valves		DN 25 - DN 40: plastic DN 50 - DN 600: cast iron
211-04	Surface box for rolling in, round, with locking bolt	-	-

For a butterfly valve indicator plate for extension spindles (9010000022), please see our website.

Installation example: buried installation

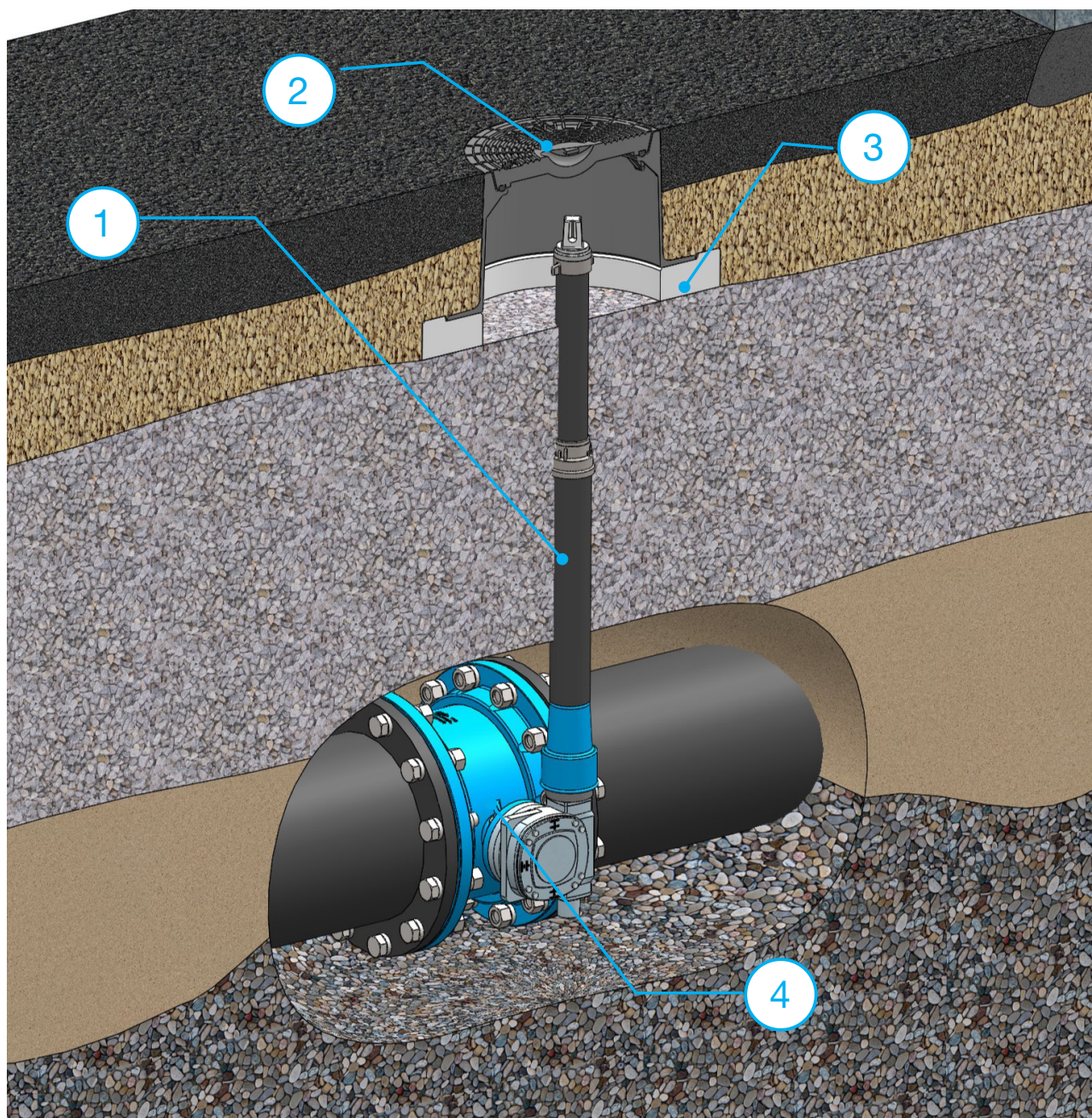

1. Extension spindle

2. Surface box

3. Base plate

4. PRO butterfly valve



Hawle Deutschland Armaturen GmbH
Liegnitzer Straße 6
83395 Freilassing
Germany

Tel.: +49 8654 6303-0

info@hawle.de
www.hawle.de/en/

® For further information on our brands, please contact us at info@hawle.de or visit our website on www.hawle.de.
We deliver based on our familiar General Terms and Conditions of Sale (GTC), which are available for downloading.
All illustrations, technical data, dimensions and weights are non-binding. Subject to change. Last updated: 03/2026