

1. Intended use / product description:

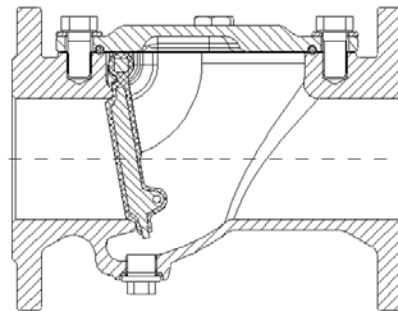

Medium: Potable water / Sewage water
Operatin temperature: 0° to 40°
Max. Betriebsdruck: 16 bar
Material: Body and cover: GJS-400/500, Hawle epoxy powder coated
 Drain plug: Stainless steel
 Valve disc: Steel/EPDM

Check valves are used to protect plant components (e.g. pumps).
 The check valve opens automatically when the medium flows in the direction indicated by the arrow (valve body) or closes automatically when the medium flows in the opposite direction to the arrow.

Face-to-face length: Basic series 48 according to DIN EN 558-1
 Flange connection dimensions: according to EN 1092-2

Min. opening pressure 0,03 bar
 Min. closing pressure 0,5 bar (Tightness)

When laying the pipes and during installation, it is necessary to refer to and comply with applicable standards and regulations, accident prevention regulations and regulations from trade associations.
 Installation can only be carried out by qualified personnel.

2. Assembly

The check valve is designed for installation in horizontal pipelines. Installation in inclined and right-hand pipelines is only permissible if the medium flows from bottom to top. Ensure that the direction of flow corresponds to the direction indicated by the arrow on the body and that the rotation axis of the valve is horizontal.

Tightening torques for cover screws

Nominal diameter	Srew	PN10 [Nm]	PN16 [Nm]
DN50	M16	70	70
DN80	M16	70	70
DN100	M16	70	70
DN125	M16	70	70
DN150	M20	70	70
DN200	M20	70	70

3. Commissioning and pressure testing

After successful installation, a pressure test must be carried out, observing the maximum operating pressures in accordance with DVGW regulations.

4. Service and maintenance

Hawle check valves are maintenance-free.

According to DVGW Code of Practice W332 and W400, visual and functional checks and the resulting maintenance work on check valves must be carried out annually and only by trained personnel.

Information on inspection and maintenance work can be found in DVGW Codes of Practice W332 and W400.

If you have any other questions or if you need more information please contact:

Hawle Armaturen GmbH

- Application Engineering -

Liegnitzer Str. 6

83395 Freilassing

Phone: +49 (0)8654 6303-0

Telefax: +49 (0)8654 6303-222

E-Mail: info@hawle.de

Web: www.hawle.de