



Hawle freeflow underground hydrant &
above ground hydrant
Example of application & Accessories

Explanations

The scope of medium can be restricted within the product data sheets. In case of any inquiry or order point out the medium of each project.

In case of any questions, don't hesitate to contact our application engineers.



potable water products



sewage water products



In general our products are subject to the statutory warranty period of two years from the day of delivery by Hawle. Due to the high quality of Hawle products we are able to offer you an extended warranty period of 5 years for our products. Further information for potable water products: www.hawle.de/en/warranty-extension



Further information of „10 years quality warranty“ for potable water products: www.hawle.de/en/10-years-quality-warranty

Freeflow underground hydrant

In case of conventional underground hydrants, water tapping and shutting off is effected in a cast iron body, with the shut-off function realized vertically via a spindle rod assembly and valve plug. In the Hawle freeflow underground hydrant, shutting off is effected by means of a shut-off blade of stainless steel.

Via an eccentric mechanism and gear the shut-off blade is moved horizontally against fixed metal stops in a body, ensuring low wear. By separating the operating pipe and the medium pipe, the hydraulic conditions in opened position in the hydrant are clearly more favourable than those in hydrants with a shut-off mechanism via valve plug.

To ensure both a high operating reliability and a long service life, the materials are chosen with particular regard to the aspect of corrosion protection. The medium

pipe and the closing element are made of stainless steel. The cast iron components are protected against corrosion through Hawle epoxy powder coating.

The freeflow underground hydrant is available with the established connection types BAIO® spigot end, flange, and PE fusion tail. Additionally, there is a connection variant with cast-on duckfoot bend. The compact design of this connection variant reduces the eddy water amount to a minimum and makes installation even easier and quicker as one pipe fitting can be omitted. The cast-on duckfoot bend is available with BAIO® spigot end and/or restraint loose flange as standard features.



Nr:	Description	Max. operating pressure	Dimension	Pipe-cover depth
490-00	Freeflow underground hydrant	16 bar	flange ¹⁾ , Spigot end DN 80; PE-fusion tail d 90, d 110	0,77 m*; 0,79 m**; 1,00 m; 1,25 m; 1,50 m *connection design: BAIO spigot end, ** connection design: flange (Special lengths on request)
490-01	Freeflow underground hydrant with integrated duckfoot bend	16 bar	DN 80	1,00 m; 1,25 m; 1,50 m (Special lengths on request)
490-02	Freeflow underground hydrant set	16 bar	flange, spigot end DN 80; PE-fusion tail d 110	1,00 m; 1,25 m; 1,50 m

1) with flange connection DN 100 on request

Freeflow underground hydrant

The unique design of Hawle freeflow underground hydrants extends the range of application to more possible uses (see page 5).

These include, for example:

- Later integration of the underground hydrant on pipelines under operating pressure
- Pipe network monitoring
- Pipe cleaning by means of sponge ball
- Drainage of pipeline by means of suction lance

Additionally, the medium pipe of stainless steel is also powder coated. Its special design provides the freeflow underground hydrant with features not present in underground hydrants of conventional make. As the rod assembly is guided outside the medium pipe, pressure losses will be lower than in case of conventional underground hydrants shut off via plugs. Apart from the conventional integration via pipe fittings, the hydrant can also be installed on pipelines under operating pressure at a later date. In this case the hydrant is installed on the pipeline via tapping sleeves, its special design provides the freeflow underground hydrant with features not present in underground hydrants of conventional make.

Technical features:

- Minimum flow rate at 1 bar differential pressure: 153 m³/h
- Min. cross section: 70 mm
- Shut-off blade with fixed stops in opened/closed position
- Spindle/claw coupling acc. to DVGW testing basis VP 325
- Drainage acc. to DIN EN 1074-6
- CE marking acc. to EN 14339
- Opening/closing: 15 revolutions acc. to EN 14339
- Pipe cover depths: standard 0.80 m to 1.50 m (special lengths on request)
- Later drilling under operating pressure possible
- Patented design

Technical data for freeflow underground

Cast components:	GJS-400, Hawle epoxy powder coated
Medium pipe:	stainless steel, Hawle epoxy powder coated
Spindle/shut-off blade:	stainless steel
Protection jacket PP:	PP (Polypropylen)
Gasket:	EPDM acc. to DVGW W 270
Medium:	potable water
Max. operating pressure:	16 bar
Lower outlet:	BAIO [®] -spigot end DN 80, Flange DN 80 ¹⁾ , PE-fusion tail d 90 / d 110
Accessories:	Dirt cover and locking ring for BAIO [®] spigot ends (490-05), Extension set (490-07), Shortening set (490-06), Drainage element (494-01; 490-03), Press-in lid alternative to hinged lid (490-09), break-away type (490-08), operating key (341-00), surface boxes (206-00; 206-01; 206-02; 211-03; 211-05)

Information: Additional cost for suction drainage device (Model No.: 4910800505) for fixed installation in ground water areas.

1) Flange DN 100 on request

Example of application

Drilling under pressure

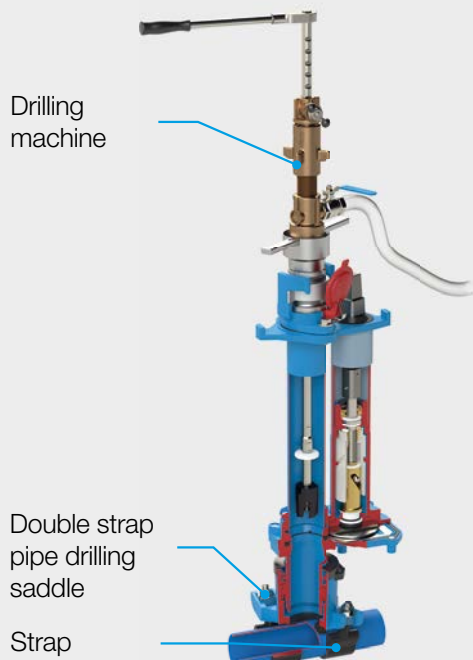

Pipeline network monitoring

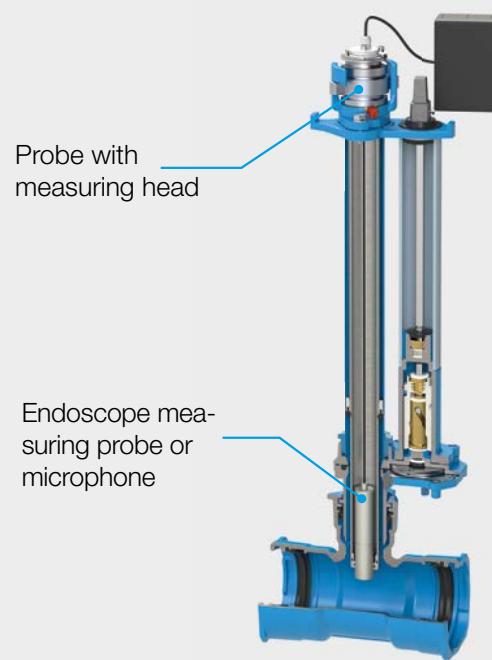

Pipe cleaning



Line drainage by means of suction lance

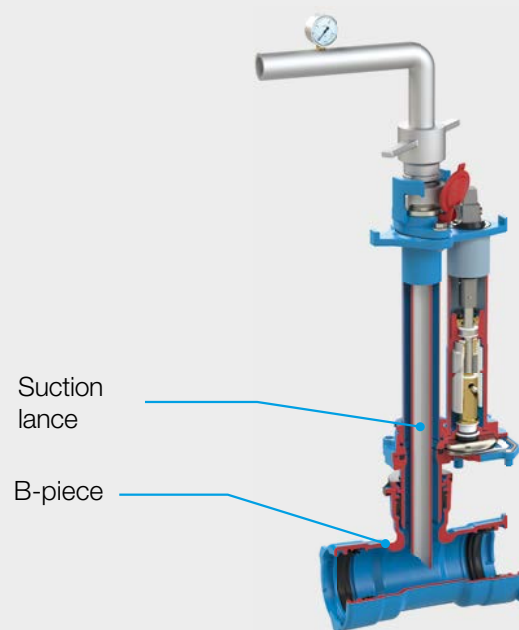

Freeflow underground hydrant „height adjustable“

The height adjustable freeflow underground hydrant features a telescopic medium pipe of stainless steel and a telescopic operating unit. Thus the underground hydrant can be adapted to the level of the road and/or of the surrounding terrain even when installed.

The adjusting range is between 0 - 300 mm and/or 0 - 550 mm, depending on the version. The medium pipe is engaged via a clamping flange with a grip ring of stainless steel, with the telescopic operating pipe being safely held via the coupling plate.

The shut-off mechanism, connection types and other possible uses of the height adjustable underground hydrant are the same as for the standard freeflow underground hydrant.

Technical features:

- Minimum flow rate at 1 bar differential pressure: 153 m³/h
- Min. cross section: 70 mm
- shut-off blade with fixed stops in opened/closed position
- Spindle/claw coupling acc. to DVGW testing basis VP 325
- Drainage acc. to DIN EN 1074-6
- Opening/closing: 15 revolutions acc. to EN 14339
- Pipe cover depths / design variants: 1.00 – 1.30 m, 1.25 – 1.55 m, 1.50 – 2.05 m, 2.00 m - 2.55 m (special lengths on request)
- Later drilling under operating pressure possible
- Connection design: BAIO[®]-spigot end, flange connection, versions with PE-fusion tail or integrated duckfoot bend, on request



Nr:	Description	Max. operating pressure	Dimension	Pipe-cover depth
494-00	Freeflow underground hydrant „height adjustable“	16 bar	Flange DN 80 ¹⁾ , Spigot end DN 80	1,00 m - 1,30 m; 1,25 m - 1,55 m; 1,50 m - 2,05 m; 2,00 m - 2,55 m

Information: Additional cost for suction drainage device (Order No.: 4910800505) for fixed installation in ground water areas

1) Flange DN 100 on request

Tele-Hydrant®

Ponding water and deposits inside surface boxes have always been problems encountered with the use of underground hydrants. In many cases, putting the standpipe onto the claw coupling will be possible only after cleaning the inside of the surface box.

Moreover, there are areas where the installation of above ground hydrants seems sensible but is impossible because of local conditions (road area, etc.)

For using the Tele-Hydrant® you only have to remove the surface box and pull the telescopic standpipe upward and above road or ground level. As the standpipe is enclosed no previous cleaning of the inside of the surface box will be required. Therefore, access time is accordingly short.

After tapping the water, the telescopic standpipe can be lowered back into the box. Thus the Tele-Hydrant® is protected in areas with increased traffic volume as well as from unauthorized use.

Just like the standard freeflow underground hydrant, the Tele-Hydrant® can be integrated into the supply network via the customary ways of connection (BAIO® spigot end, flange, and PE fusion tail) and the respective pipe fittings.

Technical features:

- telescopic standpost, integrated hydrant head
- Hydrant head can be rotated in each case by 360°
- Fixed couplings acc. to 2 x C to DIN 14317 or 2 x B to DIN 14318
- Minimum flow rate at 1 bar differential pressure: 143 m³/h (2 x C), 153 m³/h (2 x B)
- shut-off blade with fixed stops in opened/closed position
- Drainage acc. to DIN EN 1074-6
- CE marking acc. to EN 14339
- Opening/closing: 15 revolutions acc. to EN 14339
- Pipe cover depths: 1,00 m bis 1,50 m (special lengths on request)
- Connection design: BAIO®-spigot end, flanged connection versions with PE-end or cast-on duckfoot bend, on request



Nr:	Description	Max. operating pressure	Dimension	Pipe-cover depth
492-00	Tele-Hydrant®	16 bar	Flange DN 80 ¹⁾ , Spigot end DN 80	1,00 m; 1,25 m; 1,50 m

Information: Additional cost for suction drainage device (Order No.: 4910800505) for fixed installation in ground water areas

1) Flange DN 100 on request

Accessories for underground hydrant

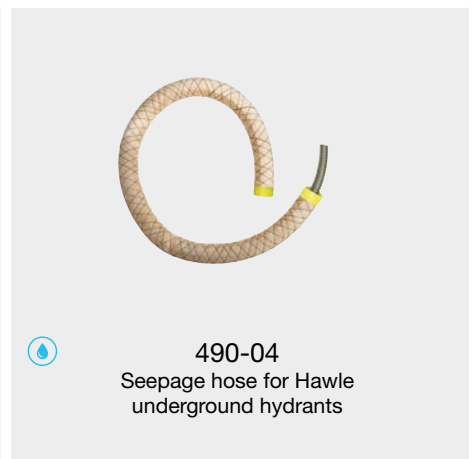
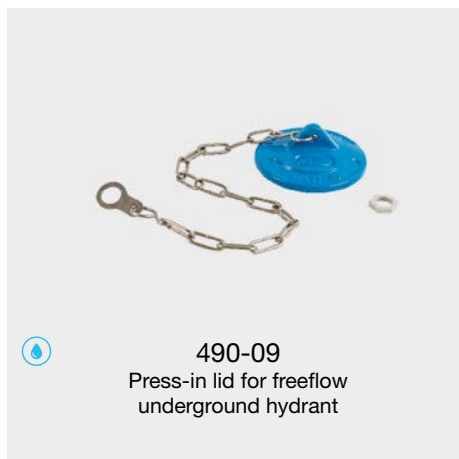
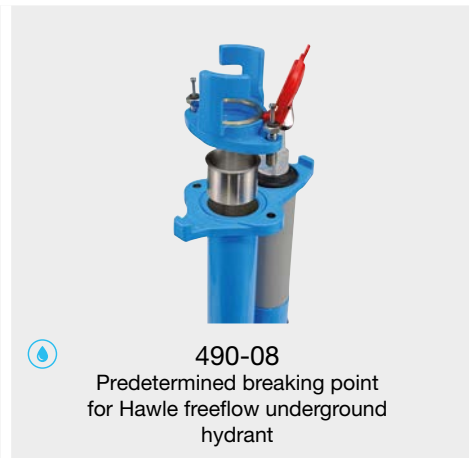
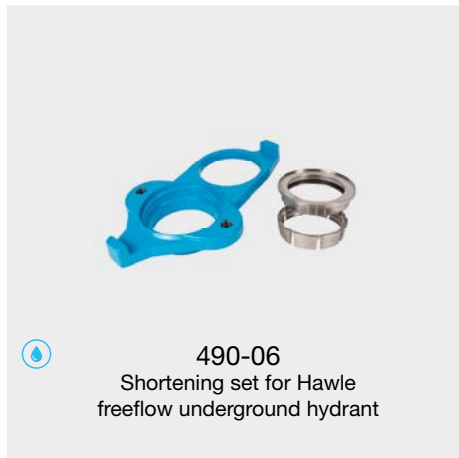

Max. operating pressure

Nr:	Description	Max. operating pressure	Characteristics
490-06	Shortening set for Hawle freeflow underground hydrant	16 bar	-
490-07	Extension set for Hawle freeflow underground hydrant ¹⁾	16 bar	Extensions: 100 mm, 150 mm, 170 mm, 200 mm, 250 mm, 300 mm, 350 mm, 400 mm, 450 mm, 500 mm (special lengths on request)
490-08	Predetermined breaking point for Hawle freeflow underground hydrant	16 bar	-
490-09	Press-in lid for Freeflow underground hydrant	-	-
490-03 494-01	Drainage element for freeflow underground hydrant and Tele-Hydrant®	-	optional accessory: Fabric bandage to prevent from clogging up the drainage element. (Best.-Nr. 490 080 0500)
490-04	Seepage hose for Hawle underground hydrants	-	length: 1600 mm

1) Note: Use special version of the extension set for Hawle Free Flow Hydrant with pipe cover depth of 0,77m / 0,79m (Order No.: 490 080 0816 und 490 081 0816)

Accessories for underground hydrant



Nr:	Description	Characteristics
490-05	Dirt cover and locking ring for BAIO® spigot ends	DN 80*
211-00	Surface box with cover, round	cover inscription: Hydrant
211-04	Surface box for rolling in, with locking bolt	cover inscription: Hydrant
204-04	Base plate of concrete for surface box model no. 211-00, 211-04	-
206-01	Surface box for rolling in, with locking bolt	cover inscription: Hydrant
206-02	Surface box for rolling in for rolling in, with locking bolt	cover inscription: Tele-Hydrant

* notice: ther is another order number for freeflow underground hydrant set 490-02

Accessories for underground hydrant



206-04
Brake ring kit for surface box for rolling in, Model No. 206-01



206-05
Surface box rigid version, with damping ring and locking bolt



204-08
Base plate Hydrant, oval DIN 4055



341-00 / 342-00
Operating key to DIN 3223

Nr:	Bezeichnung	Eigenschaften
206-04	Brake ring kit for surface box for rolling in, Model No. 206-01	-
206-05	Surface box rigid version, with damping ring and locking bolt	cover inscription: Hydrant
204-08	Base plate for hydrant surface box	-
341-00 342-00	Operating key to DIN 3223	-

Above ground hydrant DN 80, DN 100

Environmental influences like salt spreading, sand, etc., as well as extreme installation situations (e.g. in coastal areas) have always been demanding conditions for hydrants.

Hawle above ground hydrants are made exclusively of high-grade and non-corroding materials and are therefore perfectly suitable for use in coastal regions and road areas (salt spreading) as the materials chosen for them ensure high functionality.

Apart from the technical advantages, Hawle above ground hydrants of stainless steel are suitable for installation in city centres and pedestrian zones, where great store is set by a neat appearance.

Another advantage is afforded by the hydrant head. Even when the hydrant is already installed the hydrant head can be turned from 0° to 360° to align the outlets to each intermediate position.

There are advantages for stocking, transportation and installation. The materials in use points-out a significant lower weight than regular above ground hydrants made of cast iron.

All Hawle above ground hydrants with predetermined breaking point are delivered with a set of spare bolts (located in the hydrant head). The spare bolts shall be tightened at a maximum torque of 60 Nm - use of a torque wrench.

The hydrant shall be installed in such a way that the

predetermined breaking point is situated approx. 120 mm (+ - 80) above terrain level.

Technical features:

- Low weight (max. 95 kg)
- Hydrant head can be turned by 360°
- Fixed coupling acc. to DIN 14317, DIN 14318, DIN 14319
- Drain-off system with pressure control
- replaceability of the valve set
- Pipe cover depths from 1.0 m to 1.5 m (special lengths on request)
- Design variants:
 - Hydrant without predetermined breaking point
 - Hydrant with predetermined breaking point, model AU
 - Hydrant with drop jacket with predetermined breaking point, model AFU
- CE marking acc. to EN 14384
- on request:
 - desired RAL color with individual inscription possible

Technical data for above ground hydrants

Hydrant head:	514-00, 515-00, 519-00: cast iron / saltwaterproof aluminium alloy; UV resistant 517-00: shock resistant plastic with reflective foil for better visibility
Column/stand pipe:	stainless steel / lower hydrant column hawle epoxy powder coated
Valve rod:	stainless steel
Gaskets:	EPDM acc. to DVGW W 270
Medium:	potable water
max.operating pressure:	16 bar
Lower outlet:	BAIO®-spigot end DN 80 (Typ 519-00), flange DN 80, flange DN 100
Accessories:	drainage element (519-01), ratchet key (344-00), operating key (343-00)

Überflurhydranten DN 80, DN 100

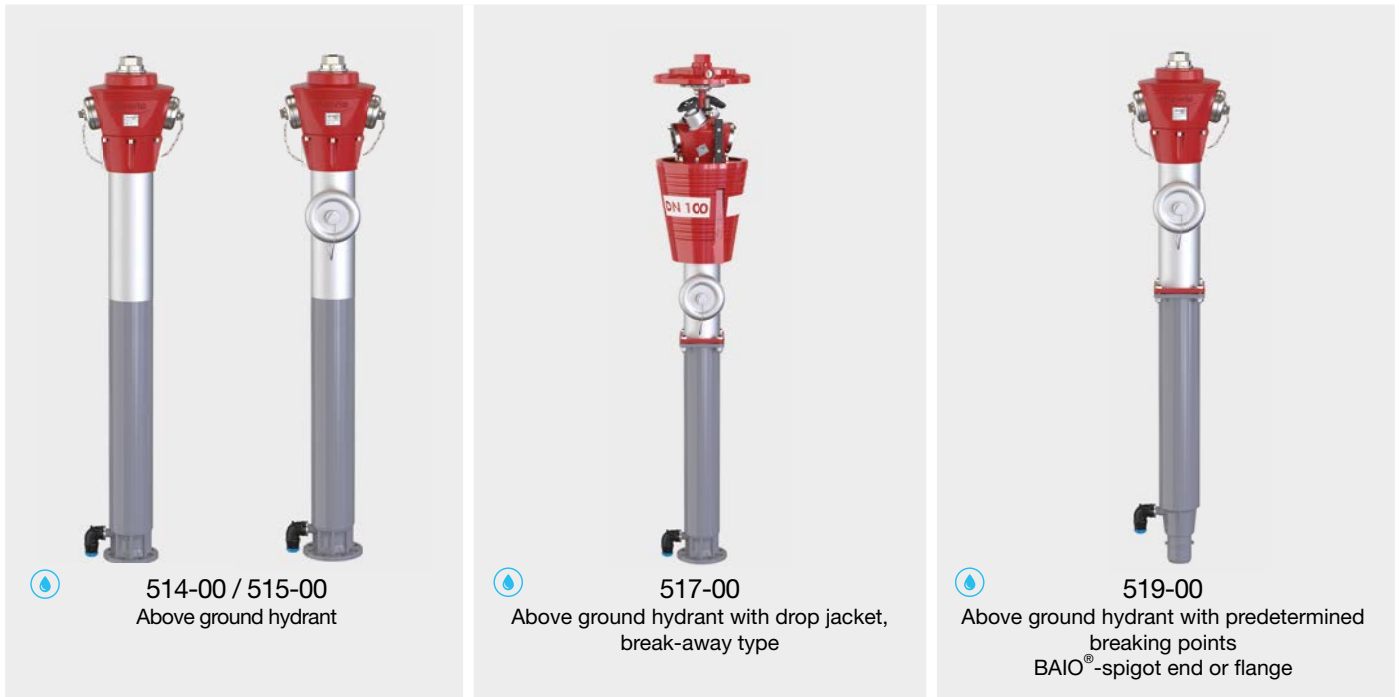

Nr:	Description	Max. operating pressure	Dimension	Pipe cover depth	Outlet
514-00 515-00	Above ground hydrant	16 bar	Flange DN 80, DN 100	1,00 m; 1,25 m; 1,50 m	514-00: 2x B 515-00: 1x B and 2x C; 1x A and 2x B
517-00	Above ground hydrant with drop jacket, break-away type	16 bar	Flange DN 100	1,00 m; 1,25 m; 1,50 m	2x B and optionally with 1x A
519-00	Above ground hydrant of stainless steel with predetermined breaking point	16 bar	Flange DN 80, DN 100; Spigot end DN 80	1,00 m; 1,25 m; 1,50 m	1x A and 2x B; 1x B and 2x C; 2x B

Above ground hydrant R1 DN 100, DN 150

In case of conventional underground hydrants, water tapping and shutting off is effected in a cast iron body, with the shut-off function realized vertically via a spindle rod assembly and valve plug. In the R1 hydrant, an annular cylinder made of stainless steel with a vulcanised on gasket undertakes the shut-off function. The design criteria for this R1 hydrant can be summarized in extraordinary durability, safe functionality, easy operation and less maintenance. And that in addition to the well known advantages of the Hawle standard hydrant quality.

Even under high pressure, the cylindrical ring design allows extremely low actuating torques.

During the opening actuating procedure the cylindrical ring moves down. While doing this the drain plug will be isolated first, and then the full port of the hydrant begins to open. Water is rising through the cylindrical ring to the top of the hydrant.

During the shut off procedure the cylindrical ring is moving up into the upper locking position, until the full port is closed. After 15 revolutions of the spindle the drainage plug opens and releases the remaining water from the R1 hydrant until no residual water is left within the hydrant body.

Technical features:

- isolation of cylindrical ring by vulcanized sealing surface
- low actuation torques
- stone trap avoid damage at the isolation mechanism
- low weight (max. 101 kg!)
- Hydrant head can be rotated in each case by 360°
- quick drainage after isolation
- easy dismantling of the cylindrical ring shut-off in case of maintenance
- Versions:
 - Above ground hydrant with break away type
 - Hydrant with drop jacket and break-away
- CE marking acc. to EN 14339
- On request:
 - Drop jacket possible in any desired RAL colour.
 - Hydrant head possible in any desired RAL colour

Technical data for R1 above ground hydrants

Hydrant head:	516-00, 516-01: cast iron / saltwater-proof aluminium alloy; UV-resistant 518-00, 518-01: shock-resistant plastic with reflective foil for better visibility
Column/stand pipe:	stainless steel / lower hydrant column hawle epoxy powder coated
Valve rod:	stainless steel
Gaskets:	EPDM acc. to DVGW W 270
Medium:	potable water
Max.operating pressure:	16 bar
Lower outlet:	flange DN 100, flange DN 150
Accessories:	drainage element (519-01), ratchet key (344-00), operating key (343-00)

Above ground hydrant R1 DN 100, DN 150

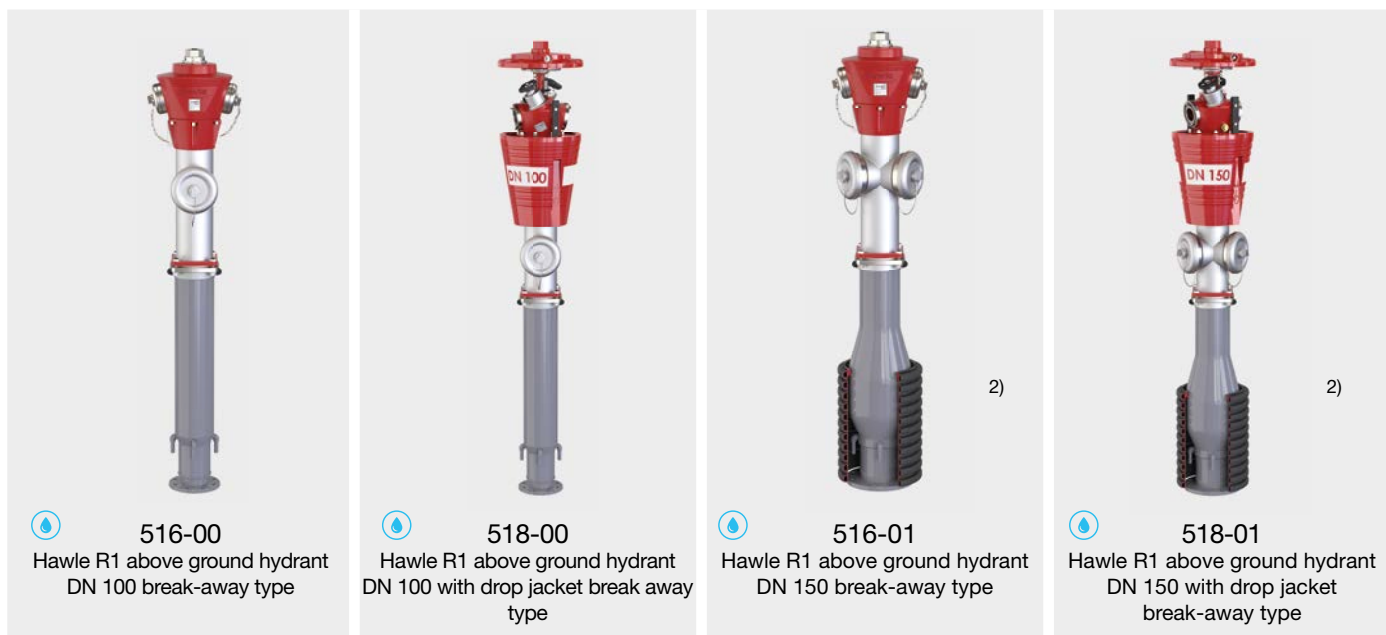

Nr:	Description	Max. operating pressure	Dimensions	Pipe-cover depth	Outlets
516-00	Hawle R1 above ground hydrant DN 100 break-away type	16 bar	Flange DN 100	1,00 m; 1,25 m; 1,50 m	2x B and optionally 1x A or 2x A ¹⁾
518-00	Hawle R1 above ground hydrant DN 100 with drop jacket break-away type	16 bar	Flange DN 100	1,00 m; 1,25 m; 1,50 m	2x B and optionally 1x A or 2x A ¹⁾
516-01	Hawle R1 above ground hydrant DN 150 break-away type	16 bar	Flange DN 150	1,00 m; 1,25 m; 1,50 m	2x B and optionally 1x A or 2x A ¹⁾
518-01	Hawle R1 above ground hydrant DN 150 with drop jacket break-away type	16 bar	Flange DN 150	1,00 m; 1,25 m; 1,50 m	2x B and optionally 1x A or 2x A ¹⁾

1) gate valve for A coupling on request

2) Article will be supplied with preinstalled drainage element

Installation example above ground hydrant R1

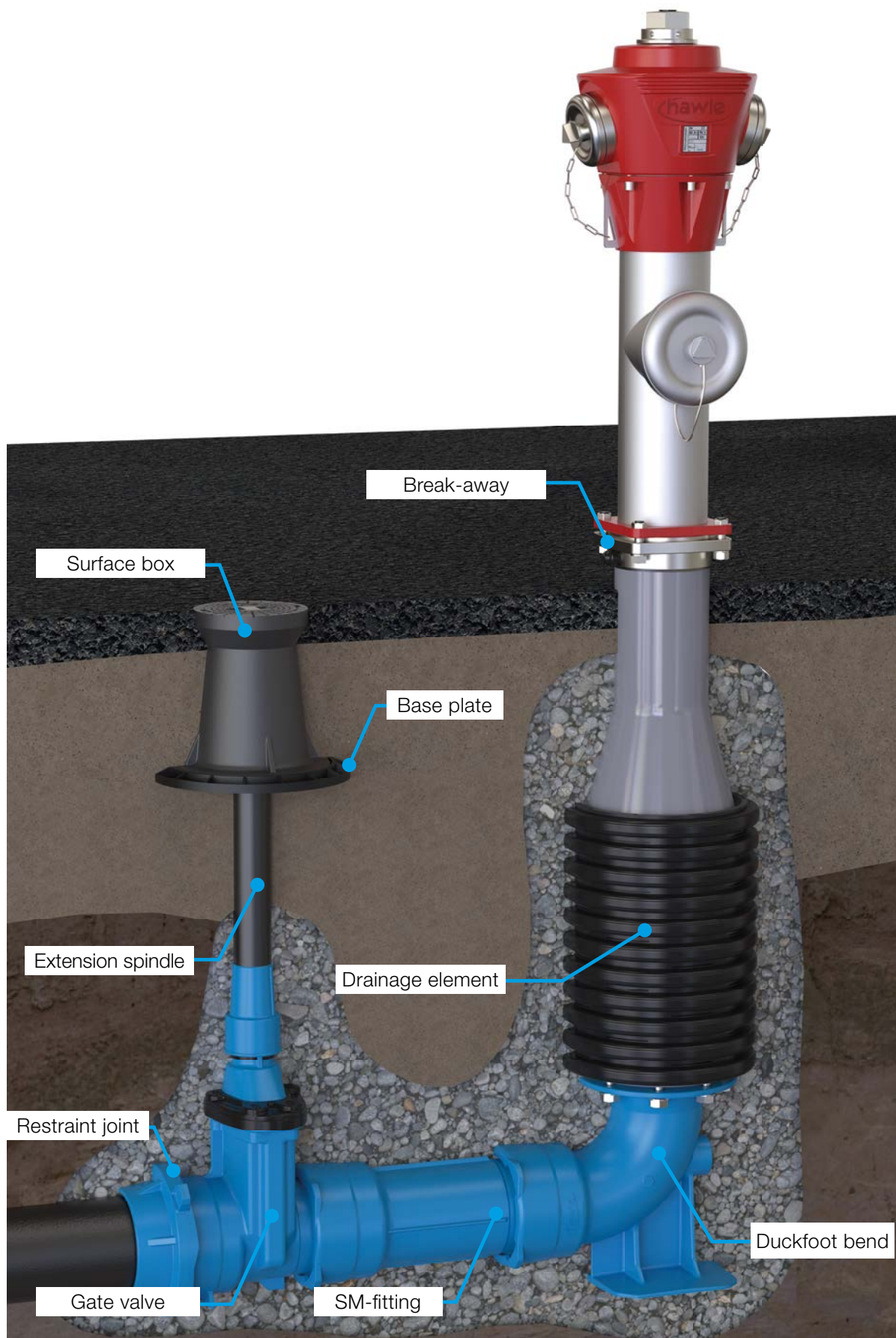

Accessories for above ground hydrant

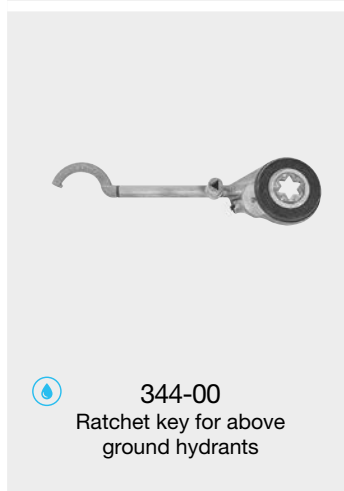
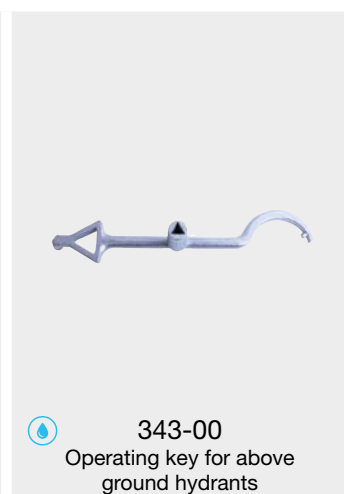

Nr:	Description	Material
519-01	Drainage element for above ground hydrant ¹⁾	PP (Polypropylen)
519-02	Hexagon head bolt for predetermined breaking point	Stainless steel
519E09	Set of spare bolts for predetermined breakingpoint above ground hydrant	Stainless steel
343-00	Operating key for above ground hydrants	Steel, galvanized
344-00	Ratchet key for above ground hydrants	Aluminium

1) Optional accessory: Fabric bandage to prevent from clogging up the drainage element (Order No.: 519 000 0700) Alternative: drainage package made of Liapor (Order No.: 519 000 0700) for standpost hydrants, article no. 514-00, 515-00, 517-00, 519-00

Flushing valve for sewage water and potable water

Via the free opening area Hawle flushing valves permit a trouble-free flushing of potable lines, culverts or transmission lines in the field of potable water. The compact design of the flushing valve makes complex and high maintenance chamber constructions unnecessary. Therefore, all the hazards related with the access of manholes can be avoided.

If the flushing valve is used for potable water applications, the surcharge for additional drainage (model no. 2400000009) has to be included on ordering (except for installation in groundwater areas where drainage is not possible).



Technical features:

- no complex construction of manholes necessary
- the hazards during entering a manhole are lapse
- easy flushing through free passage
- upper outlet with lockable C coupling, acc. to DIN 14317
- lower outlet: flange, elbow fitting 90°
- compact design, lower construction costs
- optional: with drainage outlet (for use in potable water only)



Technical data for flushing valve AW/TW

Cast components:	GJS-400, Hawle epoxy-powder coated
Medium pipe:	steel, Hawle epoxy-powder coated
Shut-off blade/Spindle:	stainless steel
C-coupling:	Aluminium
Conduit:	PE
Medium:	potable water, sewage water
Max. operating pressure:	16 bar
Lower outlet:	Flange DN 50, DN 80; flange 45°, DN 50, DN 80; Push fit elbow 90°, d 63

Nr:	Description	Max. operating pressure		Dimensions	Pipe-cover depth
					
985-04	Flushing valve for sewage water and potable water	16 bar	16 bar	Flange DN 50; DN 80; Push fit elbow d 63/90° Flange DN 50, 45°; DN 80, 45°	0,80 m; 1,00 m; 1,25 m; 1,50 m; 2,00 m; (Special lengths on request) 0,85 - 1,30 (TELE-flushing valve)

Sewage water flushing hydrant DN 80

The sewage water flushing hydrant is an adapted freeflow underground hydrant. Through the free medium pipe in opened position, this flushing hydrant allows the efficient introduction of flushing water into the sewage pressure pipe, while sewage water can be removed, for example, when a temporary bypass pipe is to be installed.

Technical features:

- no complex construction of manholes necessary
- the hazards during entering a manhole are lapse
- Special length on request
- Straight-through bore 62 mm (Storz B)

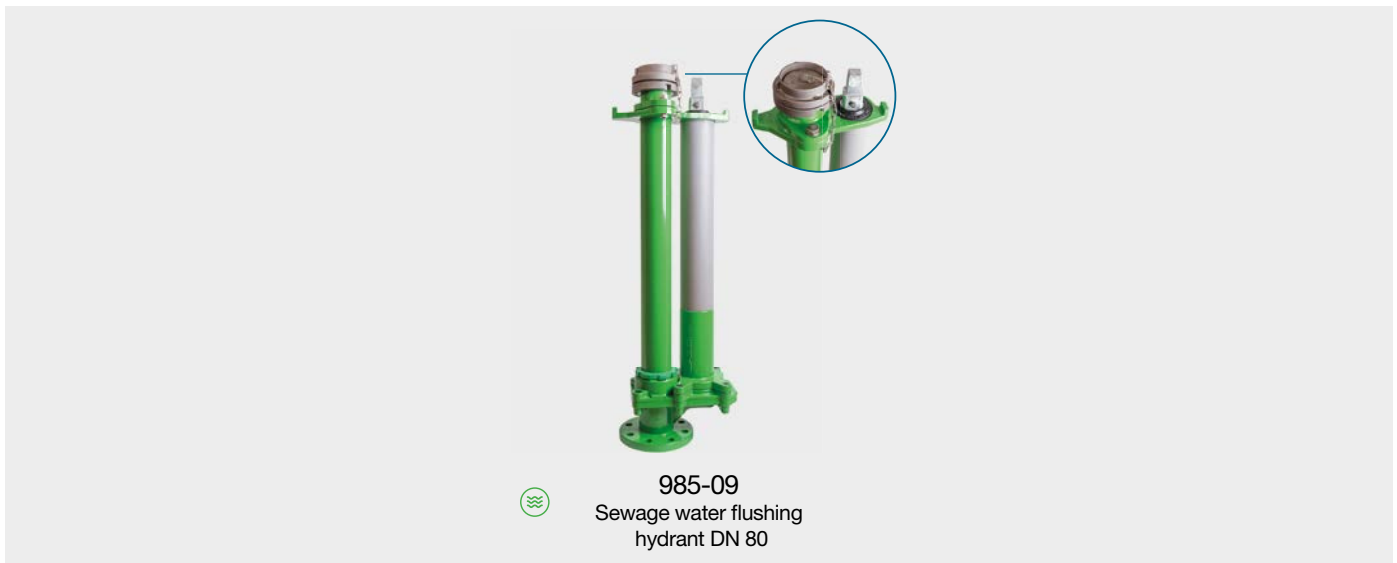

Technical data for sewage water flushing hydrant

Cast iron components:	GJS-400, Hawle epoxy-powder coated
Medium pipe:	stainless steel
Storz coupling B:	stainless steel
Sealing:	EPDM
Medium:	sewage water
max. operating pressure:	16 bar
Lower outlet:	Flange DN 80
Actuation:	with special operating key - order Nr. 3420020001

Nr:	Description	Max. operating pressure	Dimension	Pipe cover
				
985-09	Sewage water flushing hydrant DN 80	16 bar	Flange DN 80	1,00 m, 1,25 m, 1,50 m

Flushing valve for sewage water DN 100

Hawle flushing valves enable an easy flushing of pressure lines, culvert pipes, or stub lines in the water sector by means of the upper flushing connection (A- fixed coupling or Perrot coupling) and the free passage on the medium pipe.

Technical features:

- no complex construction of manholes necessary
- the hazards during entering a manhole are lapse
- piggable version on request



985-02
Flushing valve for
sewage water DN 100

Technical data for flushing valve SW DN 100

Cast iron components:	GJS-400, Hawle epoxy powder coated
Medium pipe / bracket:	stainless steel
Storz coupling B:	stainless steel
Perrot-coupling:	NW 108 galvanised steel
Seals:	NBR
Medium:	sewage water
Max. operating pressure:	10 bar
Lower outlet:	Loose flange DN 100

Nr:	Description	Max. operating pressure 	Dimension	Pipe cover
985-02	Flushing valve for sewage water DN 100	10 bar	Storz A-coupling Perrot NW 108	1,10 m; 1,25 m; 1,50 m

Irrigation hydrant

This hydrant is used to irrigate green areas / gardens. Due to the straight-through opening area high flow rates are achieved.

The medium pipe is divided in two parts and connected via a connector clamp. Actuation is effected via a telescopic extension spindle. This has the advantage that the hydrant can be quickly and easily adapted to the desired length on site. To this end only the medium pipe has to be cut to the required length, and subsequently the connection has to be re-established via the connector clamp.

Shutting off is effected via a shut-off blade of stainless steel with fixed stops in opened/closed position (PLEASE NOTE: 1/2 turn). The upper outlet with 2 1/2" female thread outlet serves the purpose of connecting standpipes with a 2 1/2" male thread outlet

Due to the drain-off function the hydrant is protected from damage by frost.

Technical features:

- ideal for use in parks/gardens
- Protected from damage by frost via drain-off function
- Later drilling under pressure possible via drilling device
- Upper connection: female thread 2 1/2"
Lower connection: flange DN 80
(Other connecting options on request)
- Spindle and shut-off blade driving mechanism made of stainless steel
- Individual adaptation of the length, pipe cover depths 1,3 - 1,8 m

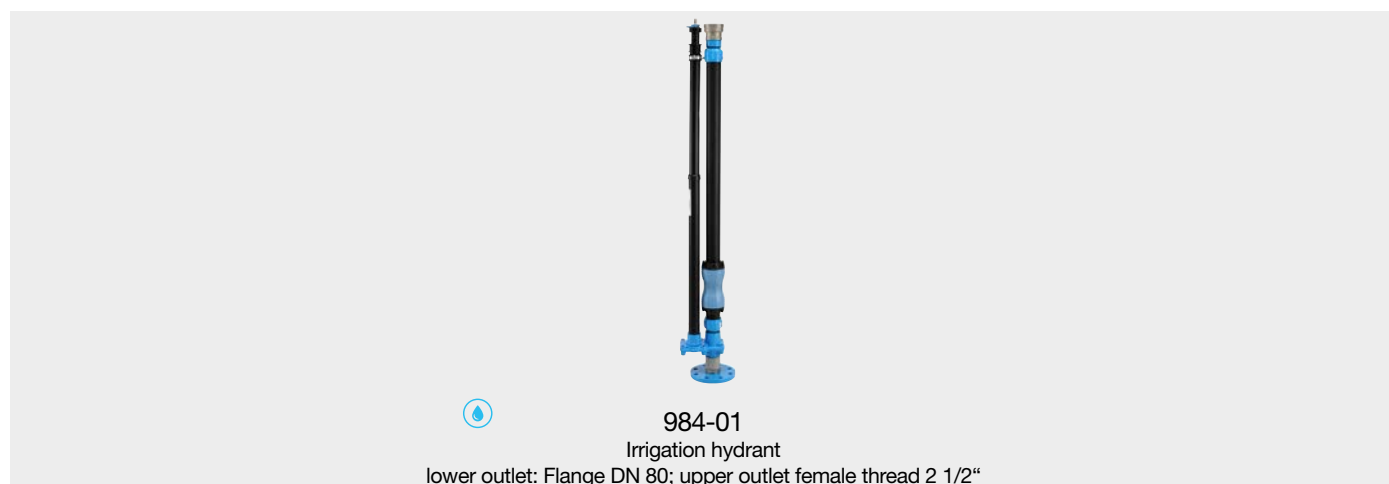

Technical data for Irrigation hydrant

Cast components:	GJS-400, Hawle-epoxy powder coated
Shut-off blade / Spindle / female	stainless steel
Conduit; medium pipe:	PE
Gaskets:	EPDM cc. to DVGW W 270
Medium:	potable water
Max. operating pressure:	16 bar
Lower outlet:	Flange DN 80
Accessories:	Drainage element (985-05), Surface box (212-00), Base plate (204-05), Operating key (341-00)

Nr:	description	Max. operating pressure 	Dimension	Pipe cover
984-01	Irrigation hydrant with flange DN 80 female thread 2 1/2"	16 bar	Flange DN 80	1,30 m - 1,80 m (Special length on request)

Freeflow garden hydrant, shortenable

This special type of hydrant serve as tapping spot for garden Irrigation. A high flow of water is guaranteed by the full open bore design.

The splitted and moveable medium pipe is connected to the telescopic extension spindle with a clamp. Both height adjustable units allow a perfect installation within the requested hight.

The isolation disc is made of stainless steel with fixed stops in open and close position (Note: 1/2 turn for operating open/close). The hydrant outlet is equipped with a GEKA coupling for connecting garden hoses. Both inlet connections are equipped with ZAK 46 sockets, in addition with two rehabilitation fittings (616-02) these garden hydrants can be retrofitted into existing service pipelines of different outside diameters.

Equipped with an ZAK end cap (249-00) this garden hydrant can be installed as and end of line valve.

Technical features:

- Protected from damage by frost via drain-off function
- upper outlet: GEKA coupling to connect garden hoses 1)
- lower outlet: ZAK 46 socket on both ends
- operate with valve key (order 341-00)

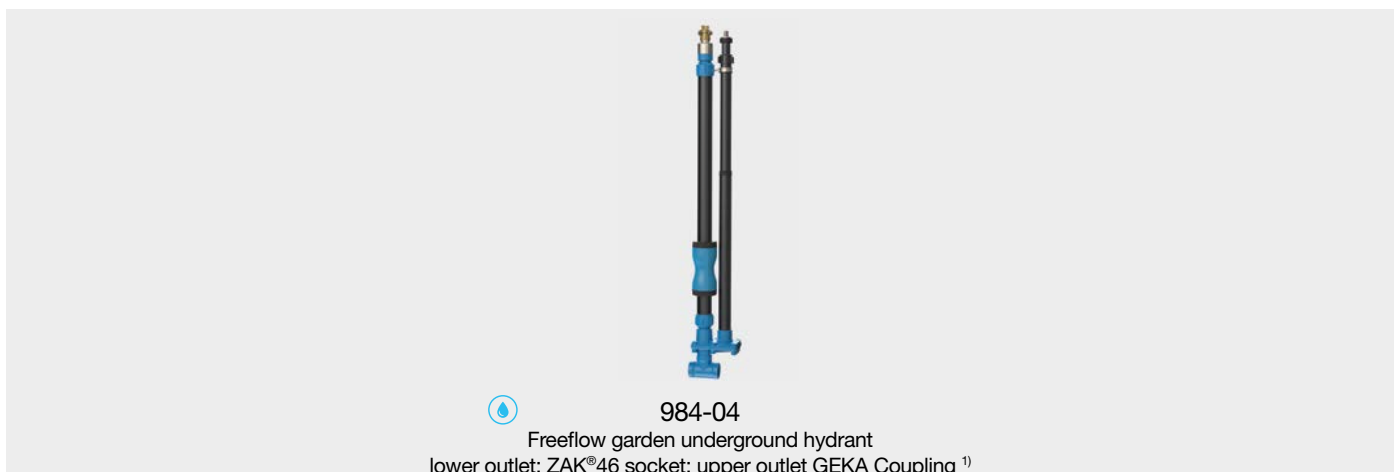

Technical data for Freeflow garden hydrant, shortened

Cast components:	GJS-400, Hawle epoxy powder coated
Protection tube, medium pipe:	PE
Shutt-off blade / spindle:	stainless steel
Gaskets:	EPDM cc. to DVGW W 270
Medium:	potable water
Max. operating pressure:	16 bar
Lower outlet:	ZAK® 46 socket, double function
GEKA-coupling ¹⁾ :	brass
Accessories:	Surface box (212-00), Base plate (204-05) and Operating key (341-00)

Nr:	Description	Max. operating pressure 	Dimension	Pipe cover
984-04	Freeflow garden underground hydrant shortenable with GEKA Coupling ¹⁾	16 bar	double function ZAK®46 socket	0,70 - 1,10 m (Special length on request)

1) Alternative: version with Franke coupling (with standpipe use) on request.

Freistrom-Gartenhydrant

The freeflow garden hydrant is perfectly suited for use in gardens and parks, as well as on camping sites.

During opening and/or closing, the shut-off blade of stainless steel is moved horizontally at low wear against fixed metal stops via a 180 degree rotation. To ensure both a high operating reliability and a long service life, the materials are chosen with particular regard to the aspect of corrosion protection. The medium pipe and the closing element are made of stainless steel. The cast iron components are protected against corrosion through Hawle epoxy powder coating.

The upper outlet with GEKA coupling is used to connect garden hoses. The free opening area allows the hydrant to be integrated later into pipelines under operating pressure,

apart from an installation in new pipelines.

Technical Features

- ideal for use in parks/gardens
- Protected from damage by frost via drain-off function
- Upper outlet:
GEKA coupling to connect garden hoses 1)
- bottom connection female thread 1 1/4" (further connections on request)
- Spindle and disc drive made of stainless steel



Technical data for freeflow garden underground

Cast components:	GJS-400, Hawle epoxy-powder coated
Medium pipe:	stainless steel
Spindle/shut-off-blade:	stainless steel
Protection jacket:	PE
Gaskets:	EPDM cc. to DVGW W 270
Medium:	potable water
Max. operating pressure:	16 bar
Lower outlet:	tapered male thread 1 1/4"
GEKA coupling ¹⁾ :	brass
Accessories:	Drainage element (984-02), Surface box (212-00), Operating key (341-00) und Base plate (204-05)

Nr:	Description	max. operating pressure 	Dimension	Pipe cover
984-00	Freeflow garden underground hydrant with GEKA coupling ¹⁾ und AG 1 1/4"	16 bar	female thread 1 1/4" conical	0,80 m; 1,00 m; 1,25 m; 1,50 m (Special length on request)

Zubehör für Spülarmaturen / Gartenhydranten



Nr:	Description	max. operating pressure		Characteristics
341-00 342-00	Operating key to acc. DIN 3223	-	-	Material: Steel, galvanized
984-02	Drainage element for garden hydrant ¹⁾	-	-	Material: PE
985-05	Drainage element for flushing valve for potable water	-	-	Material: PE
212-00	Surface box with cover, rectangular	-	-	Material: Surface box: GJL-250, bituminized Cover with gripping pins: GJS-400 Locking pin: stainless steel
204-05	Base plate of concrete for surface box model no. 212	-	-	Material: concrete
985-06	Standpipe for flushing valve 985-00	16 bar	16 bar	outlet: fixed C-coupling

1) optional accessory: Fabric bandage to prevent from clogging up the drainage element. (Order No.: 490 080 0500)



Hawle Armaturen GmbH
Liegnitzer Straße 6
83395 Freilassing
Deutschland

Tel.: +49 8654 6303-0
Fax: +49 8654 6303-111

info@hawle.de
www.hawle.de