

General Information

Hydrants and Flushing Valves

Product Categories

4.1	Underground Hydrants	4-4
4.2	Above Gound Hydrants	4-10
4.3	Flushing Valves	4-13

4.1 Underground Hydrants



General Information - Hydrants and Flushing Valves

4.1 Underground Hydrants

Freeflow underground hydrant

Today, the requirements on hydrants are manifold. Certainly, the most important aspect is the provision of water for fire-fighting. But there are also other possible uses that can be implemented by integrating special design features.

In case of conventional underground hydrants, water tapping and shutting off is effected in a cast iron body, with the shut-off function realized vertically via a spindle rod assembly and valve plug. In the Hawle freeflow underground hydrant, shutting off is effected by means of a shut-off blade of stainless steel.

Via an eccentric mechanism and gear the shut-off blade is moved horizontally against fixed metal stops in a body, ensuring low wear. By separating the operating pipe and the medium pipe, the hydraulic conditions in opened position in the hydrant are clearly more favourable than those in hydrants with a shut-off mechanism via valve plug.

To ensure both a high operating reliability and a long service life, the materials are chosen with particular regard to the aspect of corrosion protection. The medium pipe and the closing element are made of stainless steel. The cast iron components are protected against corrosion through Hawle epoxy powder coating. Additionally, the medium pipe of stainless steel is also powder-coated.

Ausführungsvarianten



Freeflow underground hydrant
(Ord. No. 490-00)



Tele-Hydrant®
(Ord. No. 492-00)

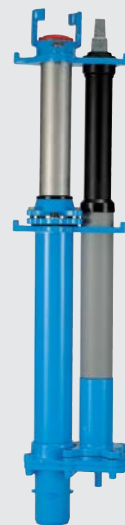

"Height-adjustable" underground hydrant
(Ord. No. 494-00)

General Information - Hydrants and Flushing Valves

4.1 Underground Hydrants

Freeflow underground hydrant, Ord. No. 490-00

Its special design provides the freeflow underground hydrant with features not present in underground hydrants of conventional make. As the rod assembly is guided outside the medium pipe, pressure losses will be lower than in case of conventional underground hydrants shut off via plugs. Apart from the conventional integration via pipe fittings, the hydrant can also be installed on pipelines under operating pressure at a later date. In this case the hydrant is installed on the pipeline via tapping sleeves, which are then drilled via the free opening area of the hydrant. Thus, complicated integration can be avoided.



Technical features

- Minimum flow rate at 1 bar differential pressure: 153 m³/h
- Min. cross section: 70 mm
- Shut-off blade with fixed stops in opened/closed position
- Spindle/claw coupling acc. to DVGW testing basis VP 325
- Drainage acc. to DIN EN 1074-6
- CE marking acc. to EN 14339
- Opening/closing: 15 revolutions acc. to EN 14339
- Pipe cover depths: standard 0.80 m to 1.50 m (special lengths on request)
- Later drilling under operating pressure possible
- Patented design

Technical data

Cast iron components:	GJS-400, Hawle epoxy powder coated
Media pipe:	stainless steel, Hawle epoxy powder coated
Shut-off blade/spindle:	stainless steel, Teflon coated
Conduit:	PP (Polypropylen)
Gaskets:	EPDM acc. to DVGW W 270
Medium:	potable water
Max. operating pressure:	16 bar
Outlet types:	BAIO® spigot end DN 80, flange DN 80, PE tail d 90 / d 110

Design variants



BAIO® spigot end



Flange connection



Integrally cast duckfoot bend (loose flange)



Integrally cast duckfoot bend (spigot end)



PE fusion tail

Cover variants

Pushed on CI cover
(article number on request)



Plastic claw cover (standard)



General Information - Hydrants and Flushing Valves

4.1 Underground Hydrants

Drilling under pressure



1. Drilling device
2. Double-strap tapping sleeve
3. Hawle strap

Pipe network monitoring

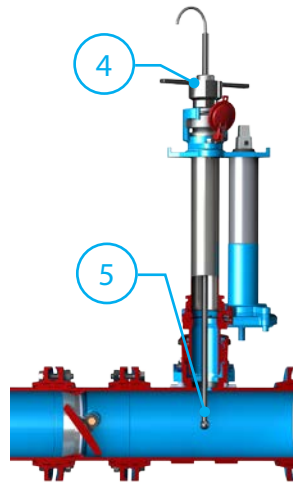

4. Measurement lock
5. Endoscope, measuring sensor or microphone

Pipe cleanin

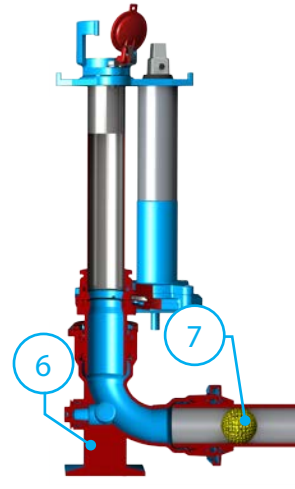

6. EN fitting
7. Pig

Drainage of line by means of suction lance

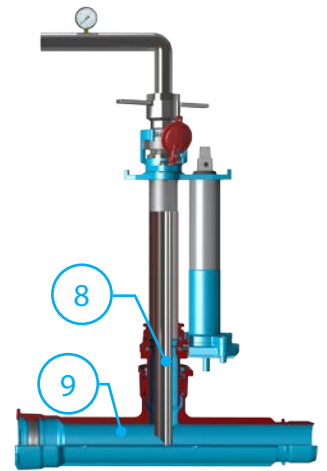

8. Suction lance
9. B fitting

Height-adjustable freeflow underground hydrant, Ord. No. 494-00

The height-adjustable freeflow underground hydrant features a telescopic medium pipe of stainless steel and a telescopic operating unit.

Thus the underground hydrant can be adapted to the level of the road and/or of the surrounding terrain even when installed.

The adjusting range is between 0 - 300 mm and/or 0 - 550 mm, depending on the version. The medium pipe is engaged via a clamping flange with a grip ring of stainless steel, with the telescopic operating pipe being safely held via the coupling plate.

The shut-off mechanism, connection types and other possible uses of the height-adjustable underground hydrant are the same as for the standard freeflow underground hydrant.

Technical features

- Minimum flow rate at 1 bar differential pressure: 153 m³/h
- Min. cross section: 70 mm
- Shut-off blade with fixed stops in opened/closed position
- Spindle/claw coupling acc. to DVGW testing basis VP 325
- Drainage acc. to DIN EN 1074-6
- Opening/closing: 15 revolutions acc. to EN 14339
- Pipe cover depths / design variants: 1.00 – 1.30 m, 1.25 – 1.55 m, 1.50 – 2.05 m, 2.00 m - 2.55 m (special lengths on request)
- Later drilling under operating pressure possible



General Information - Hydrants and Flushing Valves

4.1 Underground Hydrants

Hawle Tele-Hydrant® (underground hydrant with integral standpipe), Ord. No. 492-00

Ponding water and deposits inside surface boxes have always been problems encountered with the use of underground hydrants. In many cases, putting the standpipe onto the claw coupling will be possible only after cleaning the inside of the surface box. Moreover, there are areas where the installation of above ground hydrants seems sensible but is impossible because of local conditions (road area, etc.).

For using the Tele-Hydrant® you only have to remove the surface box and pull the integral standpipe upward and above road or ground level. As the standpipe is enclosed no previous cleaning of the inside of the surface box will be required. Therefore, access time is accordingly short.

After tapping the water, the standpipe can be lowered back into the box. Thus the Tele-Hydrant® is protected in areas with increased traffic volume as well as from unauthorized use. Just like the standard freeflow underground hydrant, the Tele- Hydrant®, can be integrated into the supply network via the customary ways of connection (BAIO® spigot end, flange, and PE fusion tail) and the respective pipe fittings.



Freeflow garden hydrant, Ord. No. 984-00

Technical features

- Ideal for use in gardens and parks, as well as on camping sites
- Protected from damage by frost via drain-off function
- GEKA coupling (other connecting options on request)
- Spindle and shut-off blade driving mechanism made of stainless steel

Technical data

Cast iron components:	GJS-400, Hawle epoxy powder coated
Medium pipe:	stainless steel
Steckscheibe/Spindel:	stainless steel
GEKA coupling:	brass
Conduit:	PE
Pipe clips:	stainless steel / rubber
Gaskets:	EPDM acc. to DVGW W 270
Medium:	water
Max. operating pressure	16 bar
Lower outlet:	tapered male thread 1 1/4" (other connections on request)



General Information - Hydrants and Flushing Valves

4.1 Underground Hydrants

Freeflow garden hydrant, shortenable, Ord. No. 984-04

Technical features

- Ideal for use in parks/gardens
- Protected from damage by frost via drain-off function
- Upper connection: GEKA coupling
- Lower connection: ZAK46 socket on both sides
- Spindle and shut-off blade driving mechanism made of stainless steel
- Individual adaptation of the length, pipe cover depths 0.7 - 1.10m



Technical data

Cast iron components:	GJS-400, Hawle epoxy powder coated
Medium pipe:	PE
Shut-off blade/spindle:	stainless steel
GEKA coupling:	brass
Conduit:	PE
Gaskets:	EPDM acc. to DVGW W 270
Medium:	water
Max. operating pressure:	16 bar
Lower outlet:	ZAK 46

Irrigation hydrant, Ord. No. 984-01

Technical features

- Ideal for use in parks/gardens
- Protected from damage by frost via drain-off function
- Later drilling under pressure possible via drilling device
- Upper connection: female thread 2 1/2"
- Lower connection: flange DN 80
- Spindle and shut-off blade driving mechanism made of stainless steel
- Individual adaptation of the length, pipe cover depths 1.3 - 1.8 m



Technical data

Cast iron components:	GJS-400, Hawle epoxy powder coated
Medium pipe:	PE
Shut-off blade/spindle:	stainless steel
Female thread socket:	stainless steel
Conduit:	PE
Gaskets:	EPDM acc. to DVGW W 270
Medium:	water
Max. operating pressure:	16 bar
Outlet types:	flange DN 80

4.2 Above Ground Hydrants



General Information - Hydrants and Flushing Valves

4.1 Above ground Hydrants

Above ground hydrant of stainless steel

Environmental influences like salt spreading, sand, etc., as well as extreme installation situations (e.g. in coastal areas) have always been demanding conditions for hydrants.

Hawle above ground hydrants are made exclusively of high-grade and non-corroding materials and are therefore perfectly suitable for use in coastal regions and road areas (salt spreading) as the materials chosen for them ensure high functionality. Additionally, the materials used have a much lower weight than conventional above ground hydrants of cast iron.

Apart from the technical advantages, Hawle above ground hydrants of stainless steel are suitable for installation in city centres and pedestrian zones, where great store is set by a neat appearance.

Another advantage is afforded by the hydrant head. Even when the hydrant is already installed the hydrant head can be turned from 0° to 360° to align the outlets to each intermediate position.

All Hawle above ground hydrants with predetermined breaking point are delivered with a set of spare bolts (in the hydrant head). The spare bolts shall be tightened at a maximum torque of 60 Nm - use of a torque wrench.

Design variants



Type 514-00/515-00
(above ground hydrant, DN 80 or DN 100 "rigid" version)



Type 519-00
(above ground hydrant, DN 80 or DN 100 with predetermined breaking point)



Type 517-00
(hydrant with drop jacket DN 100 with predetermined breaking point)



Type 516-00 / 516-01
(hydrant R1 DN 100 or DN 150 with predetermined breaking point)
figure showing DN 100



Type 518-00 / 518-01
(hydrant with drop jacket R1 DN 100 or DN 150 with predetermined breaking point)
figure showing DN 150

General Information - Hydrants and Flushing Valves

4.1 Above ground Hydrants

Above ground hydrant of stainless steel, Ord. No. 514-00, 515-00, 516-00, 516-01, 517-00, 518-00, 518-01, 519-00, 519-01

According to DVGW W 386 the hydrant shall be installed such that the predetermined breaking point is situated approx. 120 mm (+ - 80) above terrain level to ensure that it is effective.

Technical features

- Low weight (max. 101 kg!)
- Hydrant head can be turned by 360°
- Fixed coupling acc. to DIN 14317, DIN 14318, DIN 14319
- Drain-off system with pressure control and exchangeable valve assembly
- Pipe cover depths from 1.0 m to 1.5 m (special lengths on request)
- Design variants:
 - Hydrant without predetermined breaking point (514-00, 515-00)
 - Hydrant with predetermined breaking point, model AU (516-00, 516-01, 517-00, 518-00, 518-01, 519-00, 519-01)
 - Hydrant with drop jacket with predetermined breaking point, model AFU
- CE marking acc. to EN 14384



Technical data

Hydrant head:	514-00, 515-00, 516-00, 516-01, 519-00: cast iron / saltwater-proof aluminium alloy 517-00 , 518-01, 518-00: shock-resistant plastic with reflective foil for better visibility
Column/standpipe:	stainless steel
Valve rod:	stainless steel
Gaskets:	EPDM acc. to DVGW W 270
Medium:	potable water
Max. operating pressure:	16 bar
Outlet types:	BAIO® spigot end DN 80, flange DN 80, flange DN 100, flange DN 150

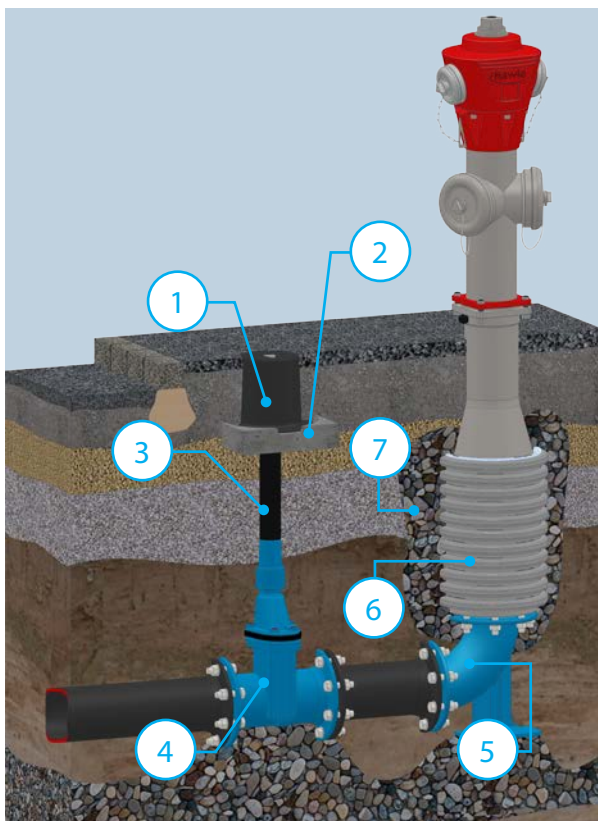

Installation example above ground hydrant R1 (DN 150)

1. Surface box
2. Base plate
3. Extension spindle
4. Shut-off valve
5. EN fitting
6. Drainage
7. Gravel layer suitable for drainage (min. grain size 5 mm)

4.3 Flushing Valves



General Information - Hydrants and Flushing Valves

4.1 Flushing Valves

Freeflow flushing valve for flushing of pressure pipes, Ord. No. 985-04

Via the free opening area Hawle flushing valves permit a trouble-free flushing of pressure lines, culverts or transmission lines in the field of water.

The compact design of the flushing valve makes complex and high-maintenance chamber constructions unnecessary. Therefore, all the dangers possibly related with the access of man-holes can be avoided. Height-adjustable flushing valve on request.



Example of application: flushing of a sewage water pressure pipe (DN 80)

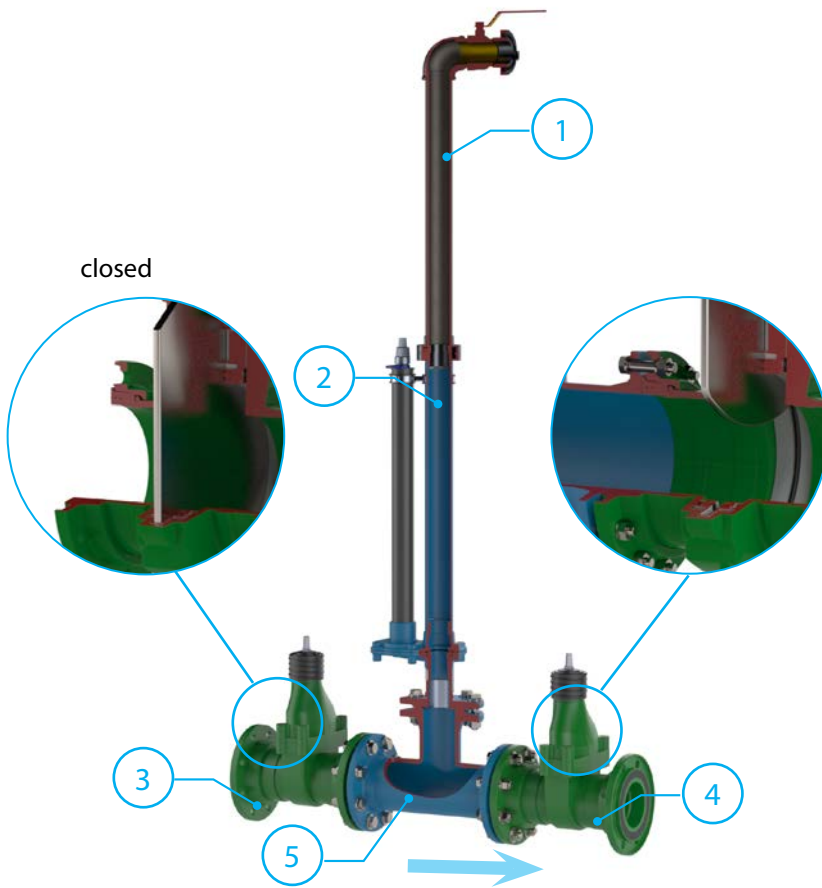

- 1: Standpipe for flushing valve (Ord. No. 985-06)
- 2: Flushing valve for sewage water and potable water (Ord. No. 985-04)
- 3: Sewage water valve closed (Ord. No. 481-00)
- 4: Sewage water valve opened (Ord. No. 481-00)
- 5: Tee

The flushing direction is determined by the different ways of shutting off the gate valve.