

1. Intended use

The ball check valve can be used for use in sewage pressure pipes (municipal sewage water), depending on the nominal width, up to a max. operating pressure of 10 or 16 bar and a max. flow velocity of 0.7 - 2 m/s. For higher flow velocities please contact us.

In addition to the operating instructions, the applicable standards and regulations, accident prevention regulations and the regulations of the employers' liability insurance associations must be observed and adhered to in both installations.

2. Machine description

The ball check valve has a loose flange which makes it much easier to replace existing non-return valves. When a new plant is built, the chamber can be made correspondingly smaller by dispensing with an extension piece.

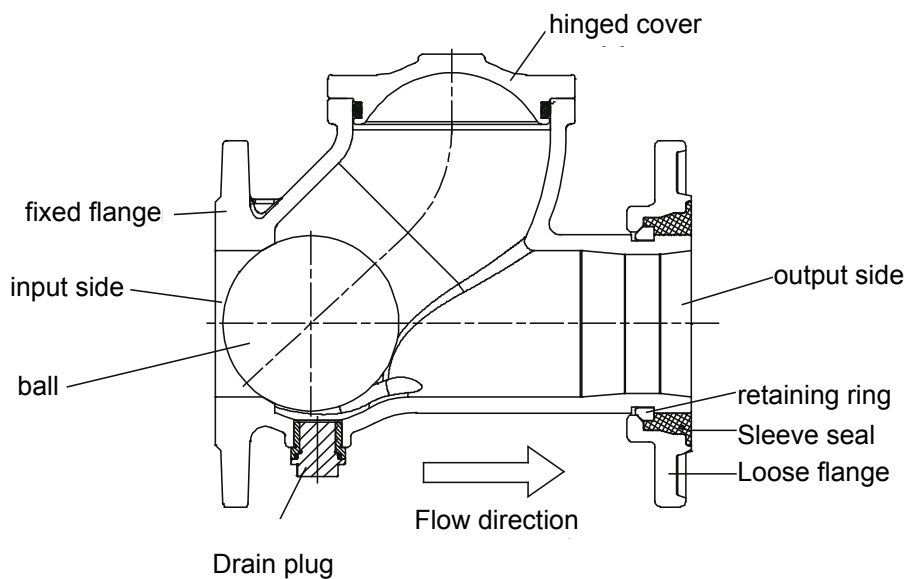

The hinged cover is easy to open and close. This prevents screws, nuts and washers from having to be loosened to such an extent that they can fall into the chamber.

For emptying or flushing the ball check valve, a 1/2" stainless steel female thread connection is provided at the bottom of the body.

The ball check valve can be installed both horizontally and vertically (recommended application). The arrow on the cast iron body indicates the direction of flow.

Horizontal installation:

For horizontal installation, the cover of the ball check valve must be on top. Without pressurisation, the bore at the ball check valve is open.

Vertical installation:

With vertical installation, the ball seals perfectly even with viscous liquids. The opening pressure, depending on the nominal diameter of the ball check valve, is shown in the following table:

DN 50 / IG 2"	DN 80	DN 100	DN 150	DN 200	DN 250	DN 300
0.006 bar	0.015 bar	0.021 bar	0.029 bar	0.037 bar	0.042 bar	0.047 bar

3. Installation/assembly

- Before installation,
 - open the hinged cover of the ball check valve
 - check the interior for foreign bodies and remove them if necessary,
 - push the ball out of its seat to ensure that it is mounted free of stress,
- then close the hinged cover again (observe max. tightening torque of 70 Nm)
- The ball check valve can be installed horizontally or vertically. The arrow on the cast iron body indicates the direction of flow. For horizontal installation, the cover of the valve must be on top.
- First attach the fixed flange of the ball check valve to the counter-flange and then attach the loose flange on the opposite side to the other counter-flange. Make sure that by turning the loose flange the hole pattern of the mating flange is overlapped and that the pipe axis and the housing axis of the ball check valve are aligned. Angles of up to 3° within the movable loose flange are permissible. Install stainless screws, nuts, washers through flange holes. By crosswise offset tightening of the screw connection an even compression between sleeve seal and counter-flange is created.

4. Service and maintenance

The ball check valve is largely maintenance-free. However, maintenance may be required if there are foreign bodies inside the ball check valve that prevent proper operation.

Caution: Prior to maintenance, ensure that the ball check valve is in a depressurized condition, disconnected from the system, and that the pumps are shut down.

Procedure:

- Slightly loosen the hexagon nut(s) on the hinged cover
- Open hinged cover
- Clean ball and check for damage and sedimentary deposition
- Check sealing seat for possible damage
- Replace the ball if necessary
- Tighten the hexagonal nut(s) with a max. torque of 70 Nm
- Put ball check valve into operation
-

5. Commissioning and pressure testing

After successful installation, a pressure test must be carried out in accordance with regulations.

If you have any other questions or if you need more information please contact:

Hawle Armaturen GmbH
- Application Engineering -
Liegnitzer Str. 6
83395 Freilassing
Phone: +49 (0)8654 6303-0
Telefax: +49 (0)8654 6303-222
E-Mail: info@hawle.de
Web: www.hawle.de