



HAWIDO - REGULATING VALVES

Instruction for

**Pressure Sustaining and Relief Valve
Type 1400**

ND40 to ND200



Keep this instruction manual at the location of the valve

Example of a nameplate

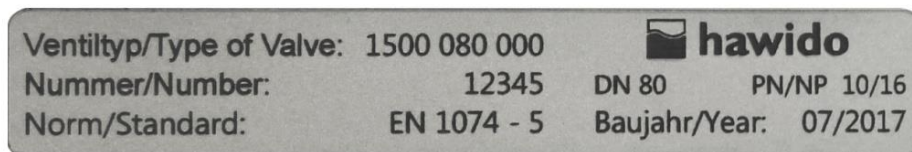

Once the commissioning work has been completed, enter the following data and always specify this additional information concerning the valve type, pressure and flow ratios, whenever you consult or have reason to question the manufacture or supplier:

Year of manufacture:..... DN: NP:

Serial number:

CONTENTS

A. DESCRIPTION	2
1. FUNCTION	2
2. GENERAL SAFETY GUIDELINES	2
3. RECOMMENDED INSTALLATION	3
B. COMMISSIONING	4
1. FUNCTIONAL DIAGRAM (1400)	4
2. PREPARATION	4
3. VENTING	5
4. ADJUSTMENTS SUSTAINABLE PRESSURE	5
5. SETTING THE REACTION SPEED	6
6. CHECKING FOR LEAKAGES	6
C. FAULT FINDING	7
D. PUTTING OUT OF SERVICE AND MAINTENANCE	8
1. PUTTING OUT OF SERVICE	8
2. MAINTENANCE AND SERVICE	8
2.1 GENERAL	8
2.2 ANNUAL CHECKS	8
2.3 FOUR OR FIVE YEARLY MAINTENANCE	9
3. REPAIR KITS AND SPARE PARTS	10
3.1 MAIN VALVE WITH STAINLESS STEEL CONNECTION ND 40 TO ND 200 (DRAWING)	11
3.2 MAIN VALVE (PARTS LIST)	12
3.3 CONTROL VALVE, PRESSURE SUSTAINING INOX (DRAWING)	14
3.4 CONTROL VALVE, PRESSURE SUSTAINING INOX (PARTS LIST)	15
3.5 CONTROL LINE AND ACCESSORIES	16
3.6 POSITION INDICATOR (DRAWING)	21
3.7 POSITION INDICATOR (PARTS LIST)	22
E. ANNEX	23
1. TORQUE TABLE	23
F. HAWLE IN EUROPE	24

A. Description

1. Function

The pressure relief valve maintains a pre-set inlet pressure (p_1) constant. Any excess system pressure is relieved by fast opening of the valve. The closing procedure is slow in order to avoid shock pressure loads. Variable flow rates have no effect on the maintained pressure which is regulated by the control valve. The overpressure or maintained pressure of the standard version can be set within the range of 1.5 bar to 12 bar.

Technical features:

Medium:	Drinking water
Pressure stages:	PN 10 (Standard DN 200 and upwards) PN 16 (Standard up to and including DN 150) PN 25
Flanges:	Connection dimensions acc. DIN EN 1092 – 2
Manometer:	EN 837-1, accuracy class 1.6
Main valve material:	EN-GJS-400-15
Temperature range:	2 to 40° C

2. General safety guidelines

The Hawle HAWIDO regulating valve is designed for use in drinking water supply systems. Please consult the manufacturer before using it with other media.

Material damage or injury to persons can occur if the HAWIDO is not installed, commissioned, operated or maintained according to these instructions or to codes of practice.

As a precondition, it is assumed that all technical regulations (e.g. SVGW, ÖVGW, DVGW...), codes of practice (e.g. VDE, VDI ...), laws and standards are understood, and will be adhered to and applied.

Work on electrical installations (e.g. installation of magnetic position switches, solenoid valves, etc.) may only be carried out by personnel authorised to carry out this work.

The responsibility for layout, installation position and commissioning of the fittings in the pipe work lies with the designer, installer and/or user. Design or installation errors can adversely affect the operation of the regulating valve and can create a significant risk. If in doubt, please consult us.

3. Recommended installation

Before the installation, all pipe work must be blown or flushed through to prevent any foreign material such as pieces of wood, stone etc. from entering the valve.

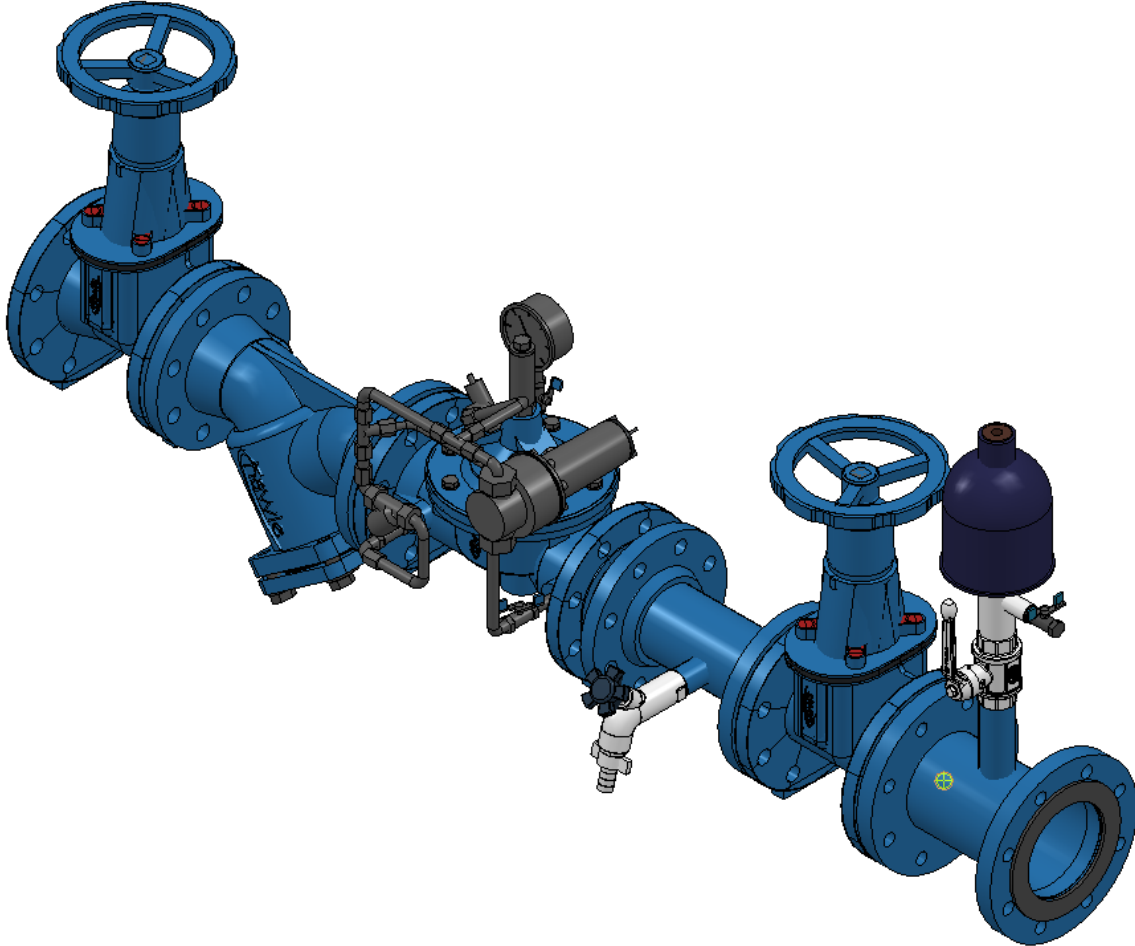

Regulating valves are normally fitted with the valve cover upwards. It is recommended that shut-off valves be fitted on both sides plus a dirt trap on the inlet side. Depending on the installation situation, a mounting adapter may also be required. If the HAWIDO 1400 is used as a relief valve, the shutoff gate valve on the outlet side can be omitted. Before commissioning, a check should be made that no coarse foreign bodies can penetrate into the HAWIDO.

For other types of installation, please contact us for advice.

B. Commissioning

1. Functional diagram (1400)

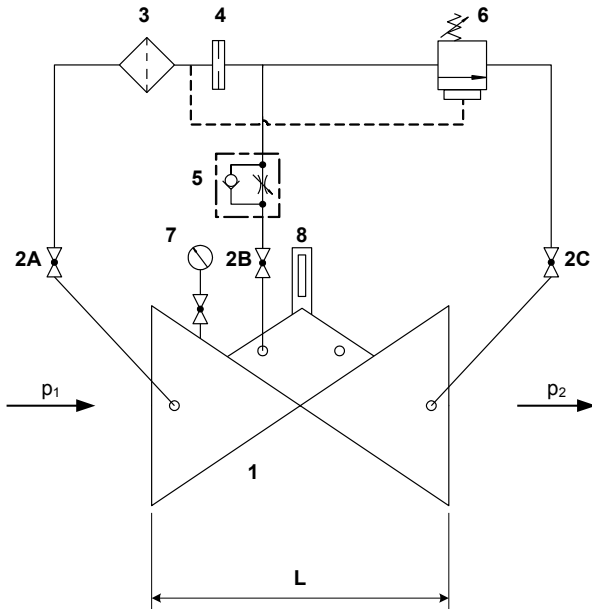

Components:

- | | |
|---|--|
| 1 | Main valve 1200 |
| 2 | Ball valve (A, B, C) |
| 3 | Filter |
| 4 | Orifice |
| 5 | One-way flow restrictor |
| 6 | Control valve |
| 7 | Pressure gauge |
| 8 | Position indicator |
| | Electrical position indicator (optional) |
| | Valve opening limiter (optional) |

2. Preparation

Before commissioning the valve, check that the gate valves on the inlet and outlet sides of the valve are closed and that the flange connections are correctly tightened and sealed.

On the main valve:

- Open the ball valves (2A, 2B)
- Loosen the lock nut on the one-way flow restrictor (5) and unscrew the adjusting screw by approx-10 turns. (The path to the control chamber is completely open).
- Close the ball valve (2C)
- Loosen the headless screw in the central plug on the position indicator.
- Loosen the headless screw in the male adaptor elbow union with venting

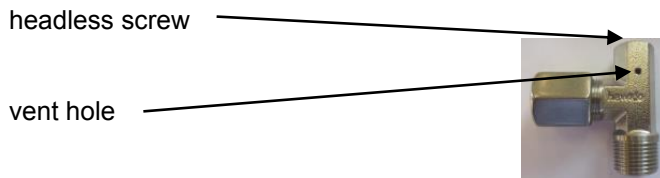

- Tip over the adjusting lever on control valve (6) and turn the lever clockwise until a very strong resistance is felt from the spring.

3. Venting

Proceed as follows:

Slowly open the inlet gate valve until water flows into the valve. The valve fills with water and the air escapes via the vent holes. When the valve venting procedure has caused all the air to be expelled from the control lines, retighten the headless screws. Check that all fittings are sealing properly and tighten if necessary.

Open the inlet valve slowly and completely.

Check:

When the outlet gate valve is opened slightly the valve should close and remain shut. Then close the gate valve again.

If the valve does not close, the commissioning procedure must be repeated from the preceding chapter onwards. Special care must be taken here to ensure that the upper valve chamber and control lines are properly vented.

4. Adjustments Sustainable Pressure

The valve is prepared according to the preceding chapter. The valve is open on the inlet side and closed on the outlet side.

Proceed as follows:

- **Slowly** open ball valve (2C). The valve then opens and fills the pipe work on the outlet side until a pressure of 0.4 bar is reached. The valve then closes again.
- **Gradually and slowly** open the gate valve on the outlet side.
- Slowly turn the adjusting lever of the control valve (6) counter-clockwise until the valve opens (audible sound of water flow).
- Check the inlet pressure on the pressure gauge.
- Step by step tighten the hand wheel of the control valve (6) (½ turn) according the table below.

Note:

Pause between each half turn of the adjusting lever until the hydraulic system has stabilised. Check the pressure on the pressure gauge on the inlet side.

If the required relief or sustaining pressure has been set, tip over the adjusting lever for fixing.

Spring	Mark	Regulating pressure	Pressure change at 1 turn [bar]	Number of spindel turns for $\Delta p = 1\text{bar}$
Standard	None	1.5 - 12bar	0.4	2.5
Strong	Yellow	10 - 22bar	0.9	1.1
Light	Blue	0.08 – 5bar	0.08	12.6

5. Setting the reaction speed

If the HAWIDO does not operate quietly, or pressure surges occur in the supply network, this can be corrected by adjustment one-way flow restrictor (5).

Procedure:

Loosen the locknut. Screw in the setting screw clockwise with a screwdriver until the valve operates quietly, and then retighten the lock nut.

Attention:

The setting screw must always remain open by at least 3 - 5 turns; otherwise the valve will not reopen sufficiently quickly after the closing sequence. A special setting may be required for very high inlet pressures.

6. Checking for leakages

HAWIDOS are tested for both leakage and functionality during manufacture. When checking for leakage under operational conditions, particular attention must therefore be given to the seals of the flange connections, the control lines and the central screw plug on the valve cover, and these must be further tightened if necessary.

C. Fault finding

Symptoms	Possible cause	Action
Valve does not open	One-way flow restrictor blocked	Replace or unscrew the set screw several times until the valve functions properly
	One-way flow restrictor closed too far	Loosen the grub screw until the valve functions properly
Valve does not close	One-way flow restrictor blocked	Replace or screw the grub set fully in and out several times, and then reset
	Filter in control circuit blocked	Clean the filter
	Air in the control lines or valve chamber	Vent system
	Foreign matter in the main valve	Carry out a service, and remove any foreign matter
	Diaphragm defective	Carry out a service, and replace the diaphragm
	Valve spindle jammed by encrustation	Carry out service, and remove any encrustation
Loud noises	Unsatisfactory operational conditions	Change pressure conditions by 0.1 to 0.2 bar. Slightly open or close the one-way flow restrictor. Contact Hawle customer service department.
	Wrong valve diameter	Calculate correct valve diameter. (If necessary contact Hawle)
Erratic operation	One-way flow restrictor incorrectly set	Reset (according to Chapter: <i>Resetting the reaction speed</i>)
Original pressure values no longer reached	Pressure gauge faulty	Check or replace pressure gauge
	Changed operating conditions	Reset accordingly (see Chapter: <i>Recommended installation</i>)
Epoxy-coating damaged	Transportation damage, installation damage	Repair using Hawle two-component repair kit for coatings

D. Putting out of service and Maintenance

1. Putting out of service

The operating valve must first be hydraulically shut off as follows:

- **Slowly** close the gate valves after and before the valve
- **Slowly** close the ball valves (2A, 2B, 2C)

The valve is taken out of operation and the maintenance can be accomplished.

2. Maintenance and Service

2.1 General

Our long experience with diaphragm valves that are controlled by the flow medium indicates that our HAWIDOs normally function trouble-free for many years. Regular maintenance is, however, necessary to ensure continued reliable operation.

Under normal operating conditions, the following should be carried out:

- Once a year, the valve should be checked for correct operation (function check)
- Once a year, the filters upstream of the valve and in the control lines should be cleaned
- Every four or five years, the inner working components should be checked, and worn parts replaced (maintenance).

Under unusual operating conditions (e.g., with water that contains quantities of suspended matter, high pressure reduction, small flow rates etc.,) maintenance should be carried out more frequently.

Maintenance label

Funktionskontrolle: jährlich	Wartung:	
Contrôle fonctionnel: annuel	Maintenance:	20xx
Prova di funzionamento: ogni anno	Mantenzione:	
Function check: annually	Maintenance:	

xx stands for the year.

2.2 Annual checks

Cleaning the strainer in the main supply

- Unscrew the lid
- Clean the filter with a brush or cloth, or replace it
- Refit the filter and screw the lid back on

Cleaning the filter in the control line

- Unscrew the lid of the filter
- Clean the filter with a brush or cloth, or replace it
- Refit the filter mesh and screw the filter lid back on

Checking the valve

- Remove the position indicator from valve cover.
- Check that the valve spindle moves easily by raising and lowering it with the threaded rod.
- Install the optical position indicator.

Putting the valve back into service

- see chapter *Commissioning*

Checking the operation of the valve

The pressure-sustaining valve has to be set eventually in such a way for the check that the inlet pressure permits the opening of the valve (see also the Chapter: *Commissioning*).

- Close the ball valve (2C) **slowly**; Valve must close.
- Open the ball valve (2C) **slowly**; Valve must open.

2.3 Four or five yearly maintenance

Cleaning the strainer in the main supply

- Unscrew the lid
- Clean the filter with a brush or cloth, or replace it
- Refit the filter and screw the lid back on

Cleaning the filter in the control line

- Unscrew the lid of the filter
- Clean the filter with a brush or cloth, or replace it
- Refit the filter mesh and screw the filter lid back on

Main valve (see chapter: *Repair kits and spare parts*)

- Undo the fittings of the control line and lay the complete control line aside.
- Disassemble the Optical Position Indicator and replace the gaskets
- Undo the screws of the valve cover and remove this valve cover.
- Visually inspect all inner components for wear, dirt and scaling
- Clean inner components, seat and inner surfaces including the valve cover
- Disassembly the spindle guide at the housing, rinse the housing interior.
For valves from DN 40 to DN 100 built in 2012 and DN 125 to DN 200 built in 2014, the spindle guide has to be removed from inside of the housing. The guiding thread of the spindle and the base valve must be **extremely clean**. Grease the thread well (eg Food Grease Aqua, Item No. 5292, see chapter control line parts and accessories).
- Replace the diaphragm, the O-ring and if necessary also the seat seal
- Thinly grease the area around the spindle guide with an agent, which is suitable for contact with foodstuffs. Check for easy movement of the spindle in the housing guide and in the cover guide.
- Assemble the main valve (See torque table in Annex). During assembly the easy movement of the spindle must be checked **several times** by actuating the threaded rod.

Disassembling the control valve (see chapter: *Repair kits and spare parts*)

- Tip over the adjusting lever
- Turn the lever counter-clockwise until no resistance from the spring can be felt
- Remove housing screw
- Replace the diaphragm, the O-ring and if necessary also the seat seal
- Visually inspect the inner surfaces of the housing and clean if necessary, including the cover
- Assemble the control valve (See torque table in Annex).

Checking the operation of the one-way flow restrictor

- Undo the locknut
- Screw in the set screw and then unscrew it as far as it goes
- Screw in again a few turns. This process must be easy and with little resistance

Putting the valve back into service

- see chapter *Commissioning*

Checking the operation of the valve

The pressure-sustaining valve has to be set eventually in such a way for the check that the inlet pressure permits the opening of the valve (see also the Chapter: *Commissioning*).

- Close the ball valve (2C) **slowly**; Valve must close.
- Open the ball valve (2C) **slowly**; Valve must open.

3. Repair kits and spare parts

Several spare parts are required for the four or five yearly maintenance. These can be obtained as a repair kit for:

- the main valve
- for the control valve
- for the control circuit
- optical position indicator

The article numbers are shown in the parts lists and spare parts lists.

Attention:

When ordering spare parts, always specify the valve type, serial number and year of manufacture.

Important:

Spare parts of EPDM (membranes, seals) and NBR (O rings) have to be stored in a dark place, protected from UV radiation!

Durability in dark storage:

EPDM: eight years after production

NBR: five years after production

3.2 Main valve (Parts list)

Item.	Description	Material	Article number				
			DN 40	DN 50	DN 65	DN 80	DN 100
1	Body	GGG 40	1004 040 000	1004 050 000	1004 065 000	1004 080 000	1004 100 000
2	Valve cover	GGG 40	1014 050 000	1014 050 000	1014 065 000	1014 080 000	1014 100 000
3	Spindle guide cover	INOX	1024 900 000	1024 900 001	1024 900 002	1024 900 003	1024 900 004
4	Spindle	INOX	1026 050 000	1026 050 000	1026 065 000	1026 080 000	1026 100 000
5	Seat	INOX	*	*	*	*	*
6	Counter seat	INOX	1044 040 001	1044 050 001	1044 065 001	1044 080 001	1044 100 001
7	Seal	EPDM	1022 040 000	1022 050 000	1022 065 000	1022 080 000	1022 100 000
8	Seal carrier	INOX	1027 040 200	1027 050 200	1027 065 200	1027 080 200	1027 100 200
9	Diaphragm PN10/16	EPDM	1020 050 000	1020 050 000	1020 065 000	1020 080 000	1020 100 000
	Diaphragm PN25	EPDM	1020 050 000	1020 050 000	1021 065 000	1021 080 000	1021 100 000
10	Pressure disc	INOX	1047 050 000	1047 050 000	1047 065 000	1047 080 000	1047 100 000
11	Nut	INOX	0007 710 080	0007 710 080	0007 712 080	0007 716 080	0007 716 080
12	Spring	INOX	1049 050 000	1049 050 000	1049 065 000	1049 080 000	1049 100 000
	Spring for valves installed upright position	INOX	1050 050 000	1050 050 000	1050 065 000	1050 080 000	1050 100 000
13	Spindle guide cover	INOX	1042 900 000	1042 900 000	1042 900 001	1042 900 002	1042 900 002
14	Hexagonal screw	INOX	0006 608 020	0006 608 020	0006 610 025	0006 610 025	0006 612 025
15	O-ring	NBR	0180 012 020	0180 012 020	0180 012 020	0180 016 020	0180 016 020
16	Washer	INOX	0008 208 000	0008 208 000	0008 210 000	0008 210 000	0008 212 000
17	GSK-sticker		1099 900 000	1099 900 000	1099 900 000	1099 900 000	1099 900 000
18	Maintenance sticker		9691 0xx 000	9691 0xx 000	9691 0xx 000	9691 0xx 000	9691 0xx 000
	Main valve complete	PN10/16	1201 040 000	1201 050 000	1201 065 000	1201 080 000	1201 100 000
	Main valve complete	PN25	--	--	1201 065 025	1201 080 025	1201 100 025
	Repair kit for main valve with stainless steel connection, comprising item 7, 9, 15, 18	PN10/16	1080 040 000	1080 050 000	1080 065 000	1080 080 000	1080 100 000
		PN25	1080 040 000	1080 050 000	1081 065 000	1081 080 000	1081 100 000

Item	Description	Material	Article number			
			DN 125	DN 150	DN 200°	DN 200^
1	Body	GGG 40	1004 125 000	1004 151 000	1004 200 000	1004 200 016
2	Valve cover	GGG 40	1014 125 000	1014 151 000	1014 200 000	1014 200 000
3	Spindle guide cover	INOX	1024 900 005	1024 900 005	1024 900 006	1024 900 006
4	Spindle	INOX	1026 125 000	1026 151 000	1026 200 000	1026 200 000
5	Seat	INOX	*	*	*	*
6	Counter seat	INOX	1044 125 001	1044 150 001	1044 200 001	1044 200 001
7	Seal	EPDM	1022 125 150	1022 151 000	1022 200 000	1022 200 000
8	Seal carrier	INOX	1027 125 200	1027 151 200	1027 200 200	1027 200 200
9	Diaphragm PN10/16	EPDM	1020 125 150	1020 151 000	1020 200 000	1020 200 000
	Diaphragm PN25	CR	1051 125 150	1051 151 000	--	1034 200 000
10	Pressure disc	INOX	1047 125 150	1047 151 000	1047 200 000	1047 200 000
11	Nut	INOX	0007 720 080	0007 720 080	0007 724 080	0007 724 080
12	Spring	INOX	1049 125 150	1049 151 150	1049 200 000	1049 200 000
	Spring for valves installed upright position	INOX	1050 125 150	1050 151 000	1050 200 000	1050 200 000
13	Spindle guide cover	INOX	1042 900 003	1042 900 003	1042 900 004	1042 900 004
14	Hexagonal screw	INOX	0006 616 035	0006 616 035	0006 620 045	0006 620 045
15	O-ring	NBR	0180 018 020	0180 018 020	0180 021 020	0180 021 020
16	Washer	INOX	0008 216 000	0008 216 000	0008 220 000	0008 220 000
17	GSK-sticker		1099 900 000	1099 900 000	1099 900 000	1099 900 000
18	Maintenance sticker		9691 0xx 000	9691 0xx 000	9691 0xx 000	9691 0xx 000
21	Retaining bracket	INOX	--	--	1200 900 020	1200 900 020
	Main valve complete	PN10/16	1201 125 000	1201 151 000	1201 200 000	1201 200 016
	Main valve complete	PN25	1201 125 025	1201 151 025		1201 200 025
	Repair kit for main valve with stainless steel connection, comprising item 7, 9, 15, 18	PN10/16	1080 125 150	1080 151 000	1080 200 000	1080 200 000
		PN25	1081 125 150	1081 151 000		1081 200 000

° PN10

^ PN16

* not interchangeable

16.03.2018/plü

3.3 Control valve, pressure sustaining INOX (drawing)

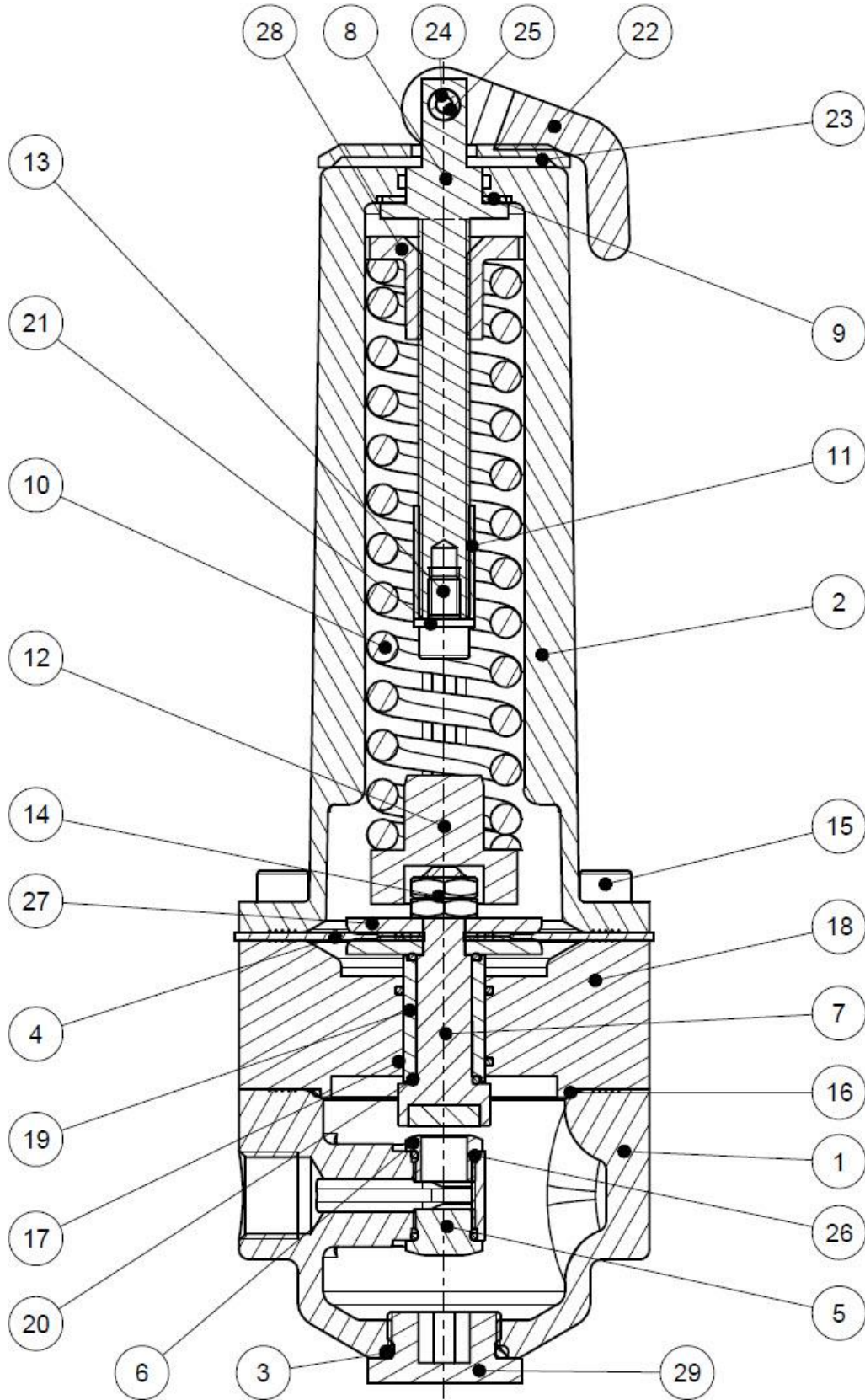

05.09.2017/plü

3.4 Control valve, pressure sustaining INOX (parts list)

Item	Description	Material	Article number
1	Control housing	INOX	1100 200 000
2	Socket	INOX	1108 200 000
3	O-Ring	NBR70	0180 020 025
4	Diaphragm DN3/8"	EPDM (W270)	1121 000 000
5	Seat Compact Form 1.0, blind	INOX	1117 200 000
6	Seat Compact Form 1.0, 9 mm	INOX	1117 200 002
7	Sealing plate DAV	INOX/EPDM	1120 200 001
8	Pressure screw	INOX	1133 200 000
9	Fibre seal	Fibre	0132 024 015
10	Compression spring standard	INOX	1145 200 000
11	Spacer sleeve to spring	INOX	1133 300 000
12	Spring guide	INOX	1133 400 000
13	Cylinder screw M6 x 10	INOX	0004 506 010
14	Hexagonal nut M8 x 0.5d	INOX	0007 208 050
15	Cylinder screw M6 x 45	INOX	0004 506 045
16	O-Ring	NBR70	0180 048 015
17	O-Ring	NBR70	0180 016 015
18	Intermediate casing	INOX	1115 016 030
19	Sleeve for axe long	Stanal 32	1140 500 000
20	O-Ring	NBR70	0180 011 015
21	Washer	INOX	0008 206 000
22	Clamping and adjusting lever	Kst – PA6.6	1135 000 001
23	Load washer	Kst – PA6.6	1135 000 010
24	Axis with female thread	INOX	1135 000 011
25	Cylinder screw M4 x 16	INOX	0004 804 016
26	O-Ring	EPDM	0180 010 015
27	Pressure washer DN 3/8"	INOX	1129 012 000
28	Screw-down nut	Rg	1134 000 010
29	Guiding pin	INOX	1137 000 000
		REGULATION RANGE:	
	Entire control valve (standard spring)	1.5 – 12 bar	1920 001 000
	Entire control valve (blue flag)	0.2 – 5 bar	1920 001 001
	Entire control valve (yellow flag)	10 – 22 bar	1900 001 002
	Repair kit comprising item: 3, 4, 7, 9, 16, 17, 20, 26		1181 000 001

05.09.2017/plü





3.5 Control line and accessories

Masternumber Description	Picture	Size more sizes might be available	Art. number
0130 Composite sealing ring		stainless steel /NBR 3/8" stainless steel /NBR 1/2" stainless steel /NBR 3/4" steel/NBR 1"	0130 012 000 0130 016 000 0130 025 000 0130 032 000
0273 Single component		Fitting attachment (consisting of connecting nut and clamping ring) DN 12 stainless steel	0273 012 000
0275 Support sleeve		stainless steel d4 – 6 stainless steel d12 – 9 stainless steel d12 – 10	0275 006 004 0275 012 009 0275 012 010
0283 Clamping ring		d6 stainless steel d12 stainless steel d18 stainless steel d8 - 6 stainless steel	0283 006 000 0283 012 000 0283 018 000 0283 008 006
0284 Orifice		d12 stainless steel Ø 0.6 mm d12 stainless steel Ø 0.9 mm d12 stainless steel Ø 1.2 mm d12 stainless steel Ø 1.5 mm d12 stainless steel Ø 1.9 mm d12 stainless steel Ø 2.4 mm d12 stainless steel Ø 3.1 mm d18 stainless steel Ø 3.5 mm d18 stainless steel Ø 4.0 mm	0284 006 000 0284 009 000 0284 012 000 0284 015 000 0284 019 000 0284 024 000 0284 031 000 0284 035 010 0284 040 010
0311 Male adaptor union		d 12 - 3/8" stainless steel d 12 - 1/2" stainless steel d 6 - 1/8" stainless steel d 6 - 1/4" stainless steel d 6 - 3/8" stainless steel d18 – 1/2" stainless steel	0311 012 012 0311 012 016 0311 006 004 0311 006 008 0311 006 012 0311 018 016
0323 Straight union		DN 6 stainless steel DN 12 stainless steel	0323 006 000 0323 012 000
0324 Straight screw-on screwed fitting		d12 - 3/8" stainless steel	0324 012 012
0351 Reduction union		d6 - d12 stainless steel	0351 012 006
0361 Female adaptor		d 10 - 3/8" stainless steel d 12 - 3/8" stainless steel d 12 - 1/2" stainless steel d 18 – 1/2" stainless steel	0361 010 012 0361 012 012 0361 012 016 0361 018 016
0371 Male adaptor		DN 12 - 3/8" stainless steel	0371 012 012

0401 Sleeve		3/8" stainless steel 1/2" stainless steel 3/4" stainless steel 1" stainless steel	0401 012 000 0401 016 000 0401 025 000 0401 032 000
0411 Adjustable male adaptor		DN 6 - 1/8" stainless steel DN12 - 3/8" stainless steel	0411 006 004 0411 012 012
0431 Male adaptor elbow union		DN 6 - 1/8" stainless steel DN6 - 1/4" stainless steel DN12 - 3/8" stainless steel DN18 - 1/2" stainless steel	0431 006 004 0431 006 008 0431 012 012 0431 018 016
0431 Male adaptor elbow union with venting		DN12 - 3/8" stainless steel	0431 012 013
0451 Elbow union 90°		DN6 stainless steel DN12 stainless steel DN18 stainless steel	0451 006 000 0451 012 000 0451 018 000
0455 Female adaptor elbow union 90°		IG 3/8" stainless steel IG 1/2" stainless steel IG 3/4" stainless steel IG 1" stainless steel	0455 012 000 0455 016 000 0455 025 000 0455 032 000
0456 Female adaptor elbow union 90°		IG 3/8" - AG 3/8" stainless steel IG 1/2" - AG 1/2" stainless steel IG 3/4" - AG 3/4" stainless steel IG 1" - AG 1" stainless steel	0456 012 000 0456 016 000 0456 025 000 0456 032 000
0461 T-union		d6 stainless steel d12 stainless steel d12 - 6 - 12 stainless steel d18 stainless steel	0461 006 000 0461 012 000 0461 012 006 0461 018 000
0510 Plug		AG 3/8" konisch stainless steel AG 1/2" konisch stainless steel	0510 012 000 0510 016 000
0511 Plug aeration for Hawido		AG 1/2" stainless steel AG 3/4" stainless steel AG 1" stainless steel (hexagon socket)	0511 016 000 0511 025 000 0511 032 001
0520 Hexagonal male adaptor nipple		d 1/8" stainless steel d 1/4" stainless steel d 3/8" stainless steel d 1/2" stainless steel d 3/4" stainless steel	0520 004 000 0520 008 000 0520 012 000 0520 016 000 0520 025 000
0541 Ball valve		DN 3/8" stainless steel DN 1/2" stainless steel DN 3/4" stainless steel	0541 012 001 0541 016 000 0541 016 010

<p>0545 Y-filter</p>		<p>Y-filter stainless steel IG 3/8" Single components: Filter sieve stainless steel Plug complete Seal big for Y-filter O-Ring</p> <p>Y-filter stainless steel 1/2"</p>	<p>0545 112 002 0545 900 051 0545 112 010 0545 112 011 0545 112 012 0545 116 000</p>
<p>0549 One-way flow restrictor & Throttle valve</p>		<p>Throttle valve DN 3/8" Brass nickel-plated</p> <p>Stainless steel IG 3/8" Typ B d 12 with a long spindle</p>	<p>0549 000 002 0549 000 005</p>
<p>0570 Non-return valve</p>		<p>3/8" Brass (max. 40 bar) 1/2" Brass (max. 40 bar)</p>	<p>0570 012 045 0570 016 045</p>
<p>0600 Manometer</p>		<p>AG 3/8" 0 - 6 bar AG 3/8" 0 - 10 bar AG 3/8" 0 - 16 bar AG 3/8" 0 - 25 bar AG 3/8" 0 - 40 bar AG 3/8" 0 - 60 bar</p>	<p>0600 012 006 0600 012 010 0600 012 016 0600 012 025 0600 012 040 0600 012 060</p>
<p>0610 Solenoid valves</p>		<p>Solenoid valve normally open 2/2 way valve (1795/96) 122K84</p> <p>Solenoid valve normally closed 2/2 way valve (1795/96) E121K04</p> <p>Solenoid valve normally open 3/2 way valve (1703 up to DN 100 1603, 1706 PN 16 all diameters) 132K04</p> <p>Solenoid valve normally closed 3/2 way valve (1704 up to DN 100, 1604) E131K04</p> <p>Solenoid valve normally open 2/2 way valve (1704 DN 125 and above 1304, 1404, 1504) (old version: E322 H73 06)</p> <p>Solenoid valve normally closed 2/2 Wegeventil (zu 1703 ab DN 125, 1303, 1403, 1503, 1706 PN 25 ab DN 125) (old version: E321 H13)</p> <p>Magnetventil universel 3/2 way valve (1706 PN 25 up to DN 100)</p> <p>*****</p> <p>Spare part : Diaphragm for solenoid type 0610 510 001 and 0610 510 002</p> <p>Spare parts Kit for solenoid valve type 0610 510 001</p>	<p>0610 122 084 0610 121 004 0610 132 004 0610 131 004 0610 510 002 0610 510 001 0610 133 005 ***** 0610 590 001 0610 590 002</p>

<p>0620 Coil</p>		<p>Coil AC voltage Indicate the voltage</p> <p>Coil DC voltage Indicate the voltage</p>	<p>0620 xxx xxx</p> <p>0621 xxx xxx</p>
<p>0630 Appliance socket for electric coil</p>		<p>Appliance socket for electric coil</p>	<p>0630 000 000</p>
<p>0652, 0653 Plug module Type LBV</p>		<p>Plug module for solenoid valves Type LBV 24 DC = 8-14S incl. 2m cable</p> <p>Plug module for solenoid valves Type LBV 24, IP 65 IN: 48-230VAC/DC OUT: 48VDC incl. 2m cable 3-wire</p> <p>For use with 48VDC coils only</p>	<p>0653 024 008</p> <p>0653 230 000</p>
<p>0670 Hexagonal overcut</p>		<p>AG 3/8" IG 1/8" stainless steel AG 3/8" IG 1/4" stainless steel AG 1/2" IG 3/8" stainless steel AG 3/4" IG 3/8" stainless steel AG 1" IG 1/8" stainless steel</p>	<p>0670 012 004 0670 012 008 0670 016 012 0670 025 012 0670 032 012</p>
<p>0671 Threaded connection</p>		<p>AG 3/8" IG 1/2" stainless steel AG 3/4" IG 1" stainless steel</p>	<p>0671 016 012 06710 32 025</p>
<p>0680 Male adaptor nipple</p>		<p>AG 3/8" L = 30 mm stainless steel AG 3/8" L = 40 mm stainless steel AG 3/8" L = 50 mm stainless steel AG 3/8" L = 60 mm stainless steel AG 3/8" L = 70 mm stainless steel AG 3/8" L = 80 mm stainless steel AG 3/8" L = 110 mm stainless steel</p>	<p>0680 012 030 0680 012 040 0680 012 050 0680 012 060 0680 012 070 0680 012 080 0680 012 110</p>
<p>0690 Male reduction nipple</p>		<p>AG 3/8" - 1/8" stainless steel AG 3/8" - 1/4" stainless steel AG 1/2" - 3/8" stainless steel AG 3/4" - 3/8" stainless steel AG 1" - 3/8" stainless steel</p>	<p>0690 012 004 0690 012 008 0690 016 012 0690 025 012 0690 032 012</p>
<p>0711 T-union</p>		<p>IG 3/8" egal stainless steel IG 1/2" egal stainless steel IG 3/4" egal stainless steel IG 1" egal stainless steel</p>	<p>0711 012 000 0711 016 000 0711 025 000 0711 032 000</p>
<p>0730 Seamless pipe</p>		<p>d6 x 1mm stainless steel d12 x 1.5 mm stainless steel d15 x 1.5 mm stainless steel d18 x 1.5 mm stainless steel</p>	<p>0730 006 010 0730 012 015 0730 015 015 0730 018 015</p>
<p>1188 Rep. Set Control line</p>		<p>From serial number 14252 (Januar 2003) DN40 bis 100 DN125 bis 300</p> <p>From serial number 25915 (Juni 2014, Filter Typ B (0545 112 002) DN40 bis 100 DN125 bis 200</p>	<p>1188 065 100 1188 125 300</p> <p>1188 000 000 1188 000 001</p>
<p>SA.0 PA-tube</p>		<p>Tube AD 6 mm, ID 4 mm Tube AD 12 mm, ID 9 mm</p>	<p>SA.0 000 060 SA.0 000 290</p>

Tools and accessories			
1199 Spindel stroke tester		M5 M6	1199 000 000 1199 000 010
1199 Tool for seal holder		Key for assembling the seal holder of the pilot valve	1199 000 020
1199 Ratchet with attachment		Ratchet with attachment for the one way flow restrictor	1199 000 030
1199 Ratchet with attachment.		Ratchet with attachment for the one way flow restrictor	1199 000 040
5292 Grease		Foodgrease Aqua Tube à 175g	5292 000 020

AG: Outside thread
IG: Inside thread

AD: Outside diameter
ID: Inside diameter

02.02.2018/plü

3.6 Position indicator (drawing)

DN 40 – DN 100

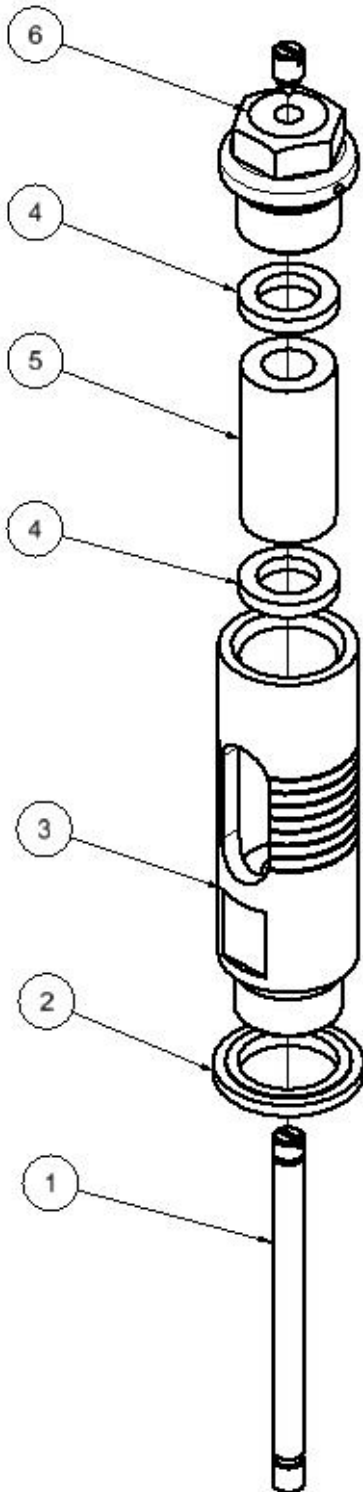

DN 125 – DN 300

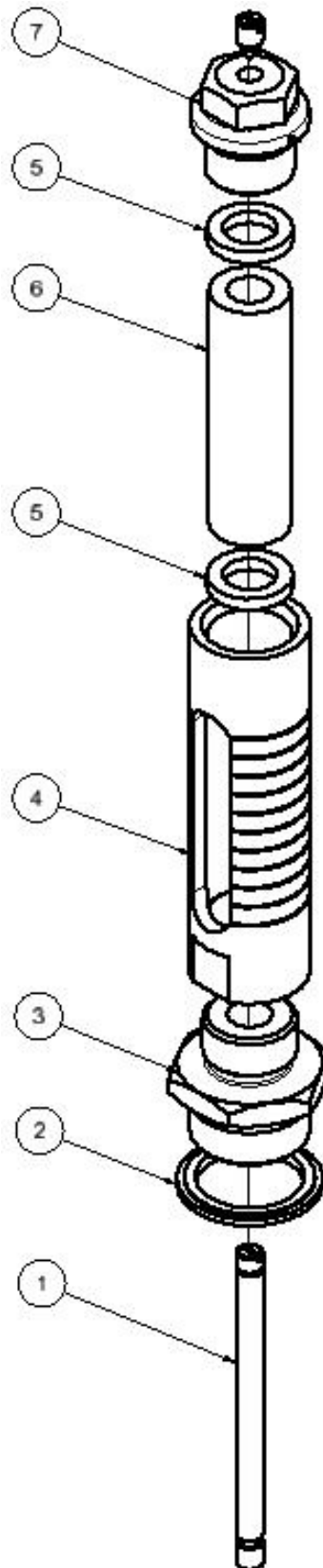

12.03.2014/plü

3.7 Position indicator (Parts list)

Item	Description	Material	Article number				
			DN 40	DN 50	DN 65	DN 80	DN 100
1	Pin	Stainl. steel	1992 000 050	1992 000 050	1992 000 080	1992 000 080	1992 000 100
2	Seal 1/2"	Stainl./NBR	0130 016 000	0130 016 000	0130 016 000	0130 016 000	0130 016 000
3	Housing	Stainl. steel	1994 000 010	1994 000 010	1994 000 010	1994 000 010	1994 000 010
4	Gasket	EPDM70	1992 900 030	1992 900 030	1992 900 030	1992 900 030	1992 900 030
5	Sight tube	Glas	1993 050 100	1993 050 100	1993 050 100	1993 050 100	1993 050 100
6	Plug 1/2"	Stainl. steel	0511 016 000	0511 016 000	0511 016 000	0511 016 000	0511 016 000
	Position indicator		1995 000 050	1995 000 050	1995 000 080	1995 000 080	1995 000 100
	Repair kit comprising items: 2 and 4		1996 000 000	1996 000 000	1996 000 000	1996 000 000	1996 000 000

Item	Description	Material	Article number				
			DN 125	DN 150N	DN 200	DN 250	DN 300
1	Pin	Stainl. steel	1992 000 125	1992 000 150	1992 000 200	1992 000 250	1992 000 300
2	Seal 3/4"	Stainl./NBR	0130 025 000	0130 025 000	0130 025 000		
	Seal 1"	Steel/NBR				0130 032 000	0130 032 000
3	Adapting nipple 3/4"	Stainl. steel	1992 900 020	1992 900 020	1992 900 020	1992 900 020	1992 900 020
4	Housing	Stainl. steel	1994 000 020	1994 000 020	1994 000 020	1994 000 020	1994 000 030
5	Gasket	EPDM70	1992 900 030	1992 900 030	1992 900 030	1992 900 030	1992 900 030
6	Sight tube	Glas	1993 125 250	1993 125 250	1993 125 250	1993 125 250	1993 300 000
7	Plug 1/2"	Stainl. steel	0511 016 000	0511 016 000	0511 016 000	0511 016 000	0511 016 000
	Position indicator		1995 000 125	1995 000 150	1995 000 200	1995 000 250	1995 000 300
	Repair kit comprising items: 2 and 5		1996 000 010	1996 000 010	1996 000 010	1996 000 020	1996 000 020

11.01.2018/plü

E. Annex

1. Torque table

When assembling the main valve and the pilot valve, all bolts are checked with a torque wrench according to the following list. Grease the bolts before mounting !

Main valve	Diameter DN	Hexagon bolt M	Streight class 1)	Tightening torque	
				Reference	Max. 2)
	40 - 50	M 8	A4 / 80	22 Nm	25 Nm
	65 - 80	M 10		47 Nm	50 Nm
	100	M 12		84 Nm	87 Nm
	125 - 150	M 16		172 Nm	216 Nm
	200	M 20		285 Nm	423 Nm
	250	M 20		285 Nm	423 Nm
300	M 20	380 Nm		423 Nm	

Pilot valve	Typ	Hexagon Socket bolt	Streight class 1)	Tightening torque	
				Reference	Max.
	DRV / DAV	M 6	A2 / A4 / 70	8 Nm	8,5 Nm
	MBV / RBS				
Control valve	Hexagon bolt M	Streight class 1)	Tightening torque		
NAZ	M 6	A2 / A4 / 70	8 Nm	8,5 Nm	

(Torque for bolts with term in head A2)

Main valve	Diameter DN	Hexagon bolt M	Streight class 1)	Tightening torque	
				Reference	Max.
	40 - 50	M 8	A2 / 70	17 Nm	19 Nm
	65	M 10		33 Nm	36 Nm
	80	M 10		40 Nm	40 Nm
	100	M 12		70 Nm	72 Nm
	125 - 150	M 16		172 Nm	172 Nm
	200	M 20		280 Nm	285 Nm
	250	M 20		280 Nm	285 Nm
300	M 20	235 Nm		240 Nm	

Note: 1) = Term on bolt head A2 – 70 or A4 – 80!

2) = Maximum permissible torque according strength analysis

Bolts according SN EN ISO 4014 und SN EN ISO 4017

Stand: FO 0065, Rev. 12 / 19.12.2017

F. Hawle in Europe

Addresses:

Hawle Armaturen AG
Hawlestrasse 1
CH-8370 Sirnach
www.hawle.ch

Telefon +41 (0)71 969 44 22
Telefax +41 (0)71 969 44 11

Hawle Armaturen GmbH
Liegnitzer Strasse 6
D-83395 Freilassing
www.hawle.de

Telefon +49 (0)8654 63 03 - 0
Telefax +49 (0)8654 63 03 60

E. Hawle Armaturenwerke GmbH
Wagrainerstr. 13
A-4840 Vöcklabruck
www.hawle.at

Telefon +43 (0)76 72/72 576 0
Telefax +43 (0)76 72 78 464

Hawle Kft
Dobogókői út 5
H-2000 Szentendre
www.hawle.hu

Telefon +36 (0) 26 501 501
Telefax +36 (0) 26 501 502

Hawle Armatury spol. s r.o.
Ricanská 375
CZ-25242 Jesenice u.Prahy
www.hawle.cz

Telefon +420 (0)2 410 03 111
Telefax +420 (0)2 41 00 33 33

Hawle Spółka zo.o
ul. Piaskowa 9
PL-62-028 Koziegłowy
www.hawle.pl

Telefon +48 (0)61 811 14 00
Telefax +48 (0)61 811 14 27

Hawle s.r.o.
Pezinská c.30
SK-903 01 Senec
www.hawle.sk

Telefon +421 (0)2 45 92 21 87
Telefax +421 (0)2 45 92 21 88

S.C. Hawle S.R.L.
Calea Sagalui 104
RO-300516 Timisoara
www.hawle.ro

Telefon +40 268 47 78 81
Telefax +40 356 80 06 68

Hawle Armaturen EOOD
Prof. Ivan Georgov Str. 1a / Fl. 2
BG-1220 Sofia
www.hawle.bg

Telefon +359 (0)2 931 12 77
Telefax +359 (0)2 931 04 36

Partners:

19.08.2014-1/plü

