



1. Intended Use / Product Description



Medium: Gas

Max. operating temperature: -10° bis 50°

Max. operating pressure: 5 bar

Material: GJS-400, Hawle epoxy powder coated

Universal pipe saddles for bladder setting device equipment with female and male thread are to be used for installation on DCI and steel pipes DN 80 - DN 500.

Adaptation to the main pipe is effected via holding strap (model no. 310-01, 314-04) and special saddle gasket drilling for max. diameter 56 mm (model no. 314-01) of the appropriate nominal width. Please indicate when ordering!

Ord.No. 352 150 0000: The standard saddle seal supplied with the bracket can be used. No special saddle seal required.

During installation and maintenance operations, the applicable standards and guidelines, accident prevention regulations and the regulations of professional associations are to be observed and complied with. Installation and maintenance operations may be performed by qualified personnel only.

Accessoires: (see separate operating instructions)

		
<p> 310-01 Hawle strap - fully vulcanized</p>	<p> 311-04 Hawle strap - stainless steel</p>	<p>314-01 special saddle gasket drilling for max. diameter 56 mm</p>

2. Assembly

⚠ ATTENTION: The HAKU pipe drilling saddle must be installed at a distance of 5x DN but must be installed at least 0.5 metres away (in accordance with DVGW W 333).

	Open-end spanner SW24, SW17, torque spanner, spirit level
---	---

Procedure for metallic pipes with coating in the area of the drilling valve

Medium gas: 

The PE coating or other coatings in the area of the tapping valve must be professionally removed down to the bare metal pipe surface in accordance with the pipe manufacturer's instructions. Any adhesive residue and unevenness on the pipe must be removed, especially in the contact area of the seal.

The strap (1) must be preformed for easier installation on the pipe.

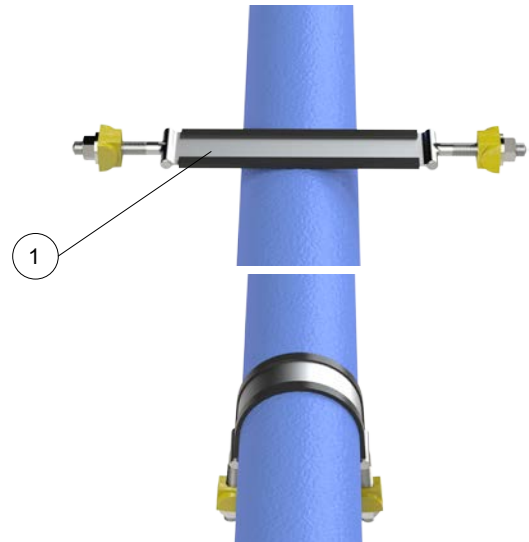

The pipe surface must be free of dirt, soil or grease.

Fit the saddle seal with fitting.

Depending on the type of pipe, hang the selected strap (1) with threaded T-piece (2), clamping jaw (3), hexagon nut (4) and washer (5) on one side of the clamp body and bend around the pipe.

Hang the strap (1) on the second side. Fit the clamping jaw (3), hexagon nut (4) and washer (5).

Place the spirit level in a suitable position on the drilling valve. When tightening the nuts, ensure that the drilling valve is aligned horizontally.

Tighten the hexagon nuts alternately and evenly with a torque of 60 - 70 Nm / max. 100 Nm.

Do not use an extension!

For Ord. no. 310-00G:
Fit protective cap for thread

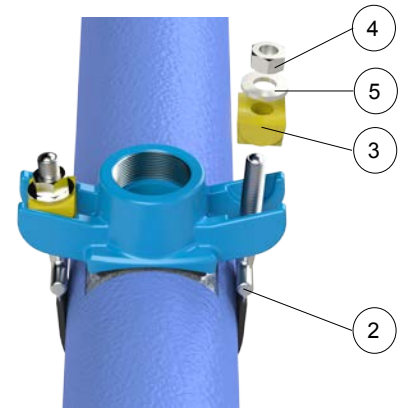

Symbol image of drilling valve



Pressure-testing

After successful installation, a pressure test must be carried out in the open pipe trench, taking into account the maximum operating pressures in accordance with DVGW regulations, in particular G469 A4 Leak test of gas house connection and gas supply lines.

Drilling with a commercially available drilling machine suitable for gas and gas bladder setting:

The following instructions / regulations must be observed:

Corresponding operating instructions for the drilling machine and gas bladder setting device:

DVGW G452-1 Drilling and shut-off work on gas pipes

BGR 500 Operation of work equipment

Explosion protection regulations

Ord.No.	Passage	max. drilling diameter
352 150 0000	41 mm	40 mm
352 163 0000	53 mm	52 mm
352 163 1000	53 mm	52 mm
352 163 2000	57 mm	56 mm
352 163 3000	57 mm	56 mm
352 163 3500	57 mm	56 mm
352 163 4000	57 mm	56 mm
352 163 5000	57 mm	56 mm

Pressure-testing

After using the gas bladder setting device, the pipe saddle must be sealed with a threaded plug with an O-ring.

A pressure test must then be carried out in the open pipe trench, taking into account the maximum operating pressures in accordance with DVGW regulations, in particular G469 A4 Leak test for gas house connections and gas supply lines.

After installing the pipe saddle, the unprotected pipe area between the strap, pipe saddle and coating must be professionally protected by post-coating measures in accordance with the pipe manufacturer's recommendations (e.g. suitable wrapping bandages, shrink hose solutions, sealing compound, coating compound) in order to prevent corrosion. These instructions apply unless the pipe manufacturers expressly provide other recommendations for their coated pipes.

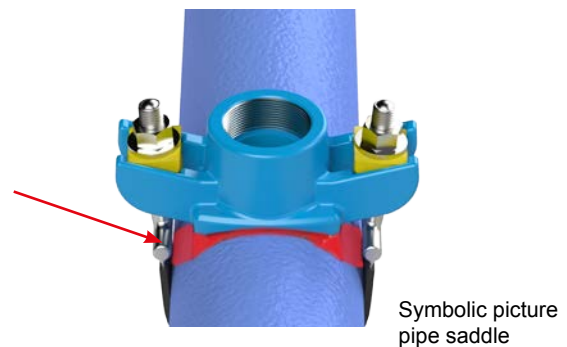

3. Inbetriebnahme und Druckprüfung

For commissioning and pressure testing, see the instructions in the installation procedure!

4. Wartung und Instandhaltung

Hawle universal pipe saddles for gas bladder setting device are maintenance-free.

If you have any other questions or if you need more information please contact:

Hawle Armaturen GmbH

- Application Engineering -

Liegnitzer Str. 6

D-83395 Freilassing

Phone: +49 (0)8654 6303-0

Telefax: +49 (0)8654 6303-222

E-Mail: info@hawle.de

Web: www.hawle.de