

Pipe drilling device
Hawlomat®

Pipe drilling device Hawlomat® 830-00

The pipe drilling device “Hawlomat” is used by default for tapping water pipes and sewage pipes made of cast iron, cement-mortar-lined cast iron, steel, cement-mortar-lined steel, PVC, PE and asbestos cement. Tapping can be performed in a range from Ø 24 mm to Ø 65 mm max. (or Ø 68 mm when using an HSS bi-metal hole saw).

In combination with a tapping fitting, drilling is possible in operating condition.

Technical details

- Hand ratchet or rotary actuator
- Drilling spindle with sliding sleeve and 3/8” thread to adapt drilling tools
- 2” internal thread for attachment of drilling adapter

Special applications

- Tapping underfloor hydrants Type 490-00
- Tapping air release valves Type 993-00
- Subsequent tapping
- Tapping 45° ZAK69
- Jigging borehole sleeves
- Jigging borehole sealing sleeves

Technical data

Medium:	potable water, municipal sewage (according to EN 1085)
Operating temperature:	0° - 40°C
Max. operating pressure:	16 bar
Material:	see List of parts
Connection variants:	1“ - 2“ / ZAK 34 - ZAK 69, other connection variants available on request

Components of the Hawlomat® - Basic unit in the Systainer (830-01)

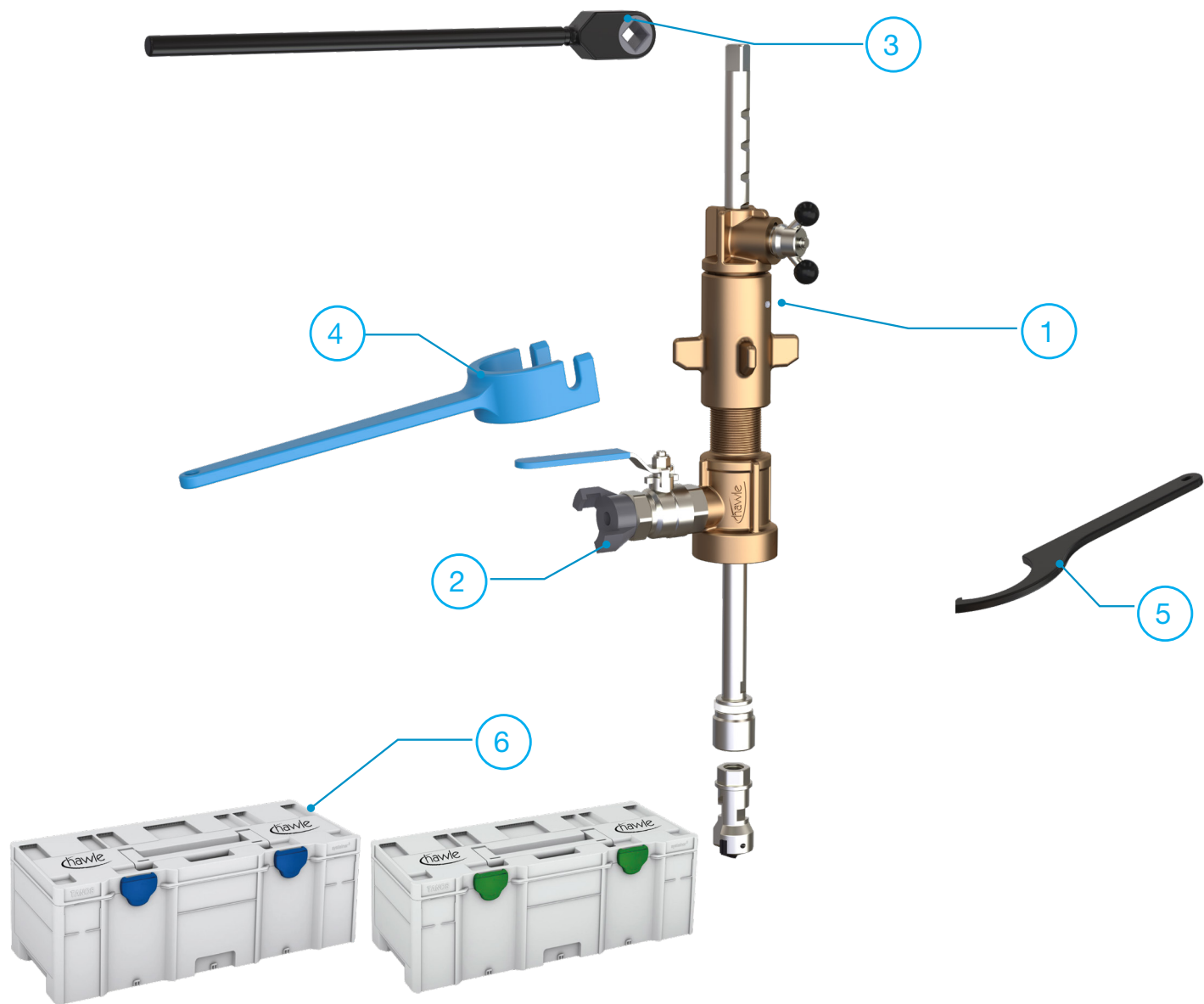

No.	Component	Material
1	Pipe drilling device Hawlomat (830-00)	
2	Ball valve and GEKA threaded piece	stainless steel
3	Hand ratchet	steel / tool steel
4	Feed wrench	steel / Hawle epoxy powder coated or
5	Hook spanner	steel
6	Systainer - potable water or sewage	Plastic with foam inlay

Pipe drilling device Hawlomat® - Accessories

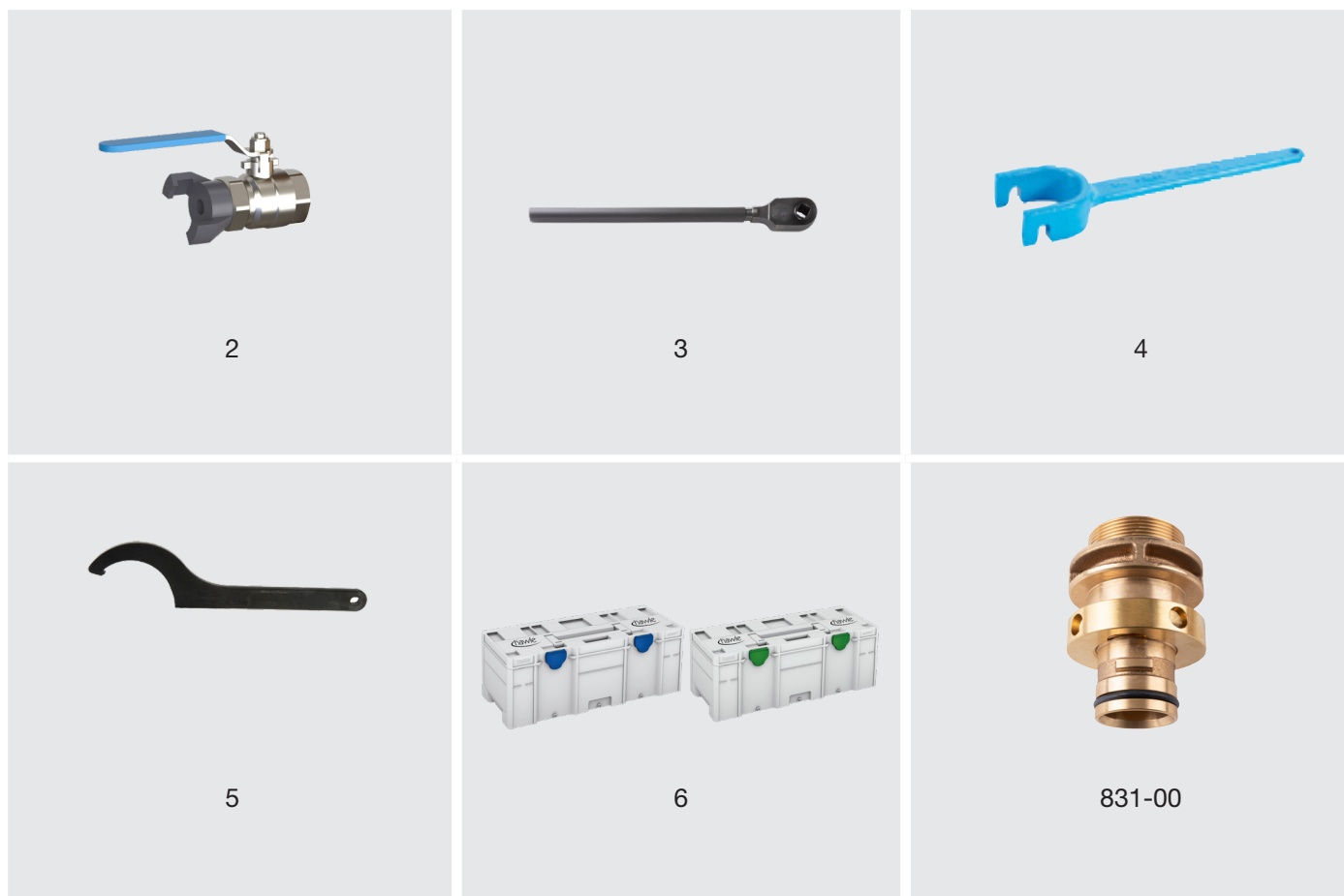

No.	Description
2	Flush valve with GEKA coupling (included in basic unit 830-01)
3	Hand ratchet (included in basic unit 830-01)
4	Feed wrench (included in basic unit 830-01)
5	Hook spanner (included in basic unit 830-01)
6	Systainer with foam inlay for potable water and sewage (included in basic unit 830-01)
831-00	Drilling adapter (see separate overview table)

Pipe drilling device Hawlomat® - Drilling tools



Type 100



Type 101



Type 102



Type 103



Type 104



Type 105

No.

Description

Type 100	HSS hole milling cutter Ø64 (Order no. 831100...)
Type 101	HSS hole milling cutter Ø24 to Ø50 (Order no. 831101...)
Type 102	HSS hole milling cutter Ø24 to Ø45 (Order no. 831102...)
Type 103	HSS bimetal hole saw Ø24 to Ø68 (Order no. 831103...)
Type 104	HM hole milling cutter Ø36 to Ø65 (Order no. 831104...)
Type 105	HSS drill bit Ø24 to Ø45 (Order no. 831105...)

For notes and use of drilling tools and accessories for 831-00, see separate overview table.

Pipe drilling device Hawlomat® - Drilling tools

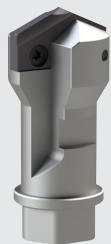

Type 106



Type 107

No.	Description
Type 106	HM interchangeable plate drill Ø24 to Ø36 (Order no. 831106...)
Type 107	Forstner drill bit Ø40 and Ø50 (Order no. 831107...)

For notes and use of drilling tools and accessories for 831-00, see separate overview table.

Hawle Deutschland Armaturen GmbH
Liegnitzer Straße 6
83395 Freilassing
Deutschland

Tel.: +49 8654 6303-0

info@hawle.de
www.hawle.de/en



© For further information on our brands, please contact us at info@hawle.de or visit our website on www.hawle.de.
We deliver based on our familiar General Terms and Conditions of Sale (GTC), which are available for downloading.
All illustrations, technical data, dimensions and weights are non-binding. Subject to change. Last updated: 02/2026